



EBARA

CS1860EE

HIGH PRESSURE DOUBLE CASE PUMPS

Horizontally Split Inner Casing, Multi Stage
For Boiler Feed, Process and Other High Pressure Services

Models

HSB/HDB **API 610**

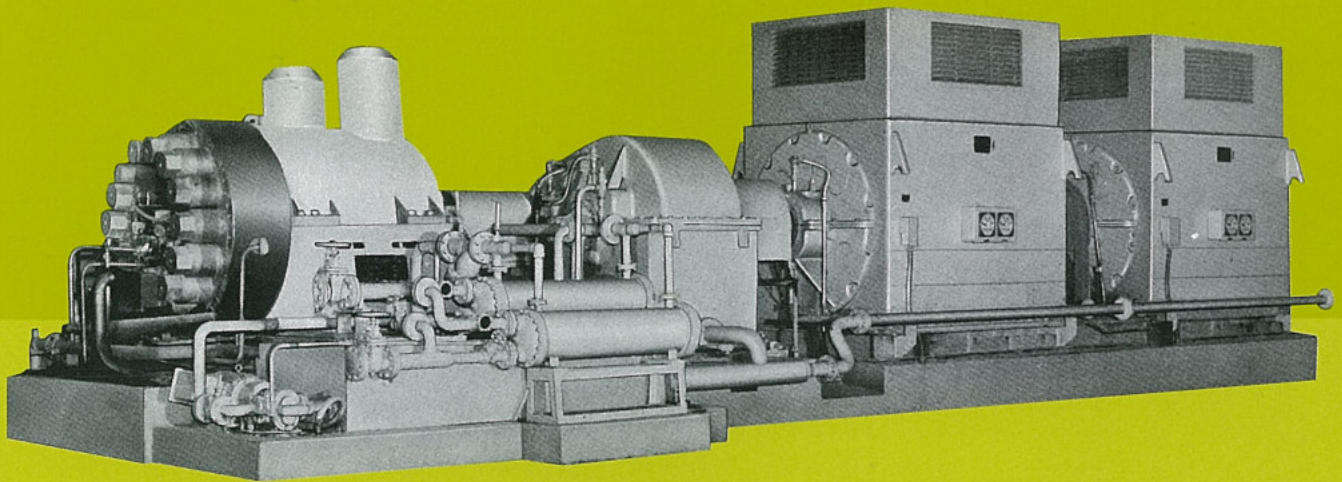

HIGH PRESSURE DOUBLE CASE PUMPS

Horizontally Split Inner Casing, Multi Stage For Boiler Feed, Process and Other High Pressure Services.

Models

HSB/HDB

API 610

EBARA HIGH PRESSURE DOUBLE CASE PUMPS MODEL HSB/HDB with Horizontally split inner casing multi stage and centerline support have been widely used in boiler feed, process, de-scaling and other high pressure services for many years.

More than 1000 units of model HSB/HDB were provided for such high pressure services in the world including the highest pressure boiler feed pumps and de-scaling pumps.

Our modern mass production facilities enable us to pass the cost saving on to you.

The unique design of this high performance pump provides for superior and extended low cost operation.

Model HDB denotes double suction impeller type for 1st stage.

Application

- Boiler Feed
- Process
- De-scaling
- Other High Pressure Services.

Ratings

Capacities:	As required for any service
Heads:	As required for any service
Discharge pressures:	Gauge 16.7MPa(2420PSIG)and up
Speeds:	As required
Rotation:	Clockwise and counter-clockwise
Temperatures:	As required
Type impeller:	Enclosed
Nozzle:	Top-top standard with other nozzle placement available
Flanges:	Welding with other standards available
Shaft sealing:	Throttle bushing, mechanical seal & conventional packing

Features

- High pressure and temperature reliability
- Centerline supported for heavy duty operation
- Flexibility of design handles wide range of liquids
- All components have been designed for maximum parts interchangeability
- Full compliance with API610 specifications

Construcion

Cold Pump Start-up. Two-piece horizontally split inner-volute construction offers advantages of cold start-up...concentric running clearances (which can be checked with feeler gauge). Rotating elements are dynamically balanced as an assembly before installation.

Designed for High Pressure. Only forged-steel barrel and discharge cover are exposed to full discharge pressure. Welded suction and discharge nozzles can be located at top or bottom for best main piping layout.

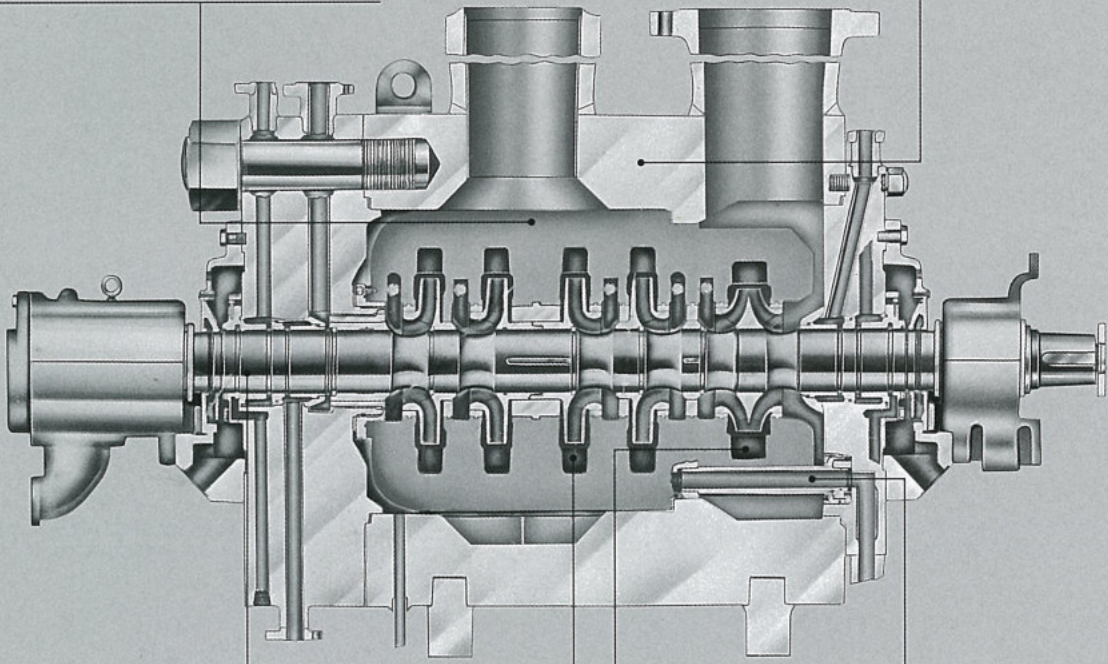

Choice of Shaft Seals. Exclusive design of throttle bushings with cold-condensate injection ensure reliable service, minimum maintenance and remarkably low wear. Also available-conventional packing for lower service requirement...and mechanical seals developed especially for boiler feed service.

Less Downtime. For maximum reliability, reduced maintenance and lowest noise level, double-action pivot-shoe thrust bearing and self-align, lubricated, babbitt-lined radial bearings are standard.

Optional Booster Impeller. Provides high-pressure spray water for steam attemperation.

Optional Attemperator Tap. Pump stage can be tapped to provide water spray for hot reheat steam line temperature control.

Low NPSH. First-stage double-suction impeller ensures low NPSH requirements. (Also available in Type HSB single-suction first-stage impeller)

Inherent Axial Balance for High Reliability. Because of opposed impeller grouping, axial hydraulic thrust is inherently balanced over full operating range without use of close-clearance balancing device. Therefore, no external bleed-back piping to a low-pressure point in the system is required.

Metallurgy

Name of part	Materials ASTM-AISI		
	C.Steel	13% Cr-Steel	316 S. Steel
Outer Casing	ASTM A105/A266	ASTM A105/A266	ANSI 316
Inner Casing	ASTM A216 WCB	ASTM A478 CA6NM	ASTM A351 CF8M
Casing Cover	ASTM A105/A266	ASTM A105/A266	ANSI 316
Impeller	ASTM A478 CA6NM	ASTM A478 CA6NM	ASTM A351 CF8M
Shaft	ASTM A276 410H	ASTM A276 410H	ANSI 316
Case Wear Ring	ASTM A743 CA40	ASTM A743 CA40	ANSI 316

Note: Other materials supplied on request.

Design Features

- quick and uniform preheating
- axial balance without use of balancing devices
- radial balance through double volute construction
- ease of assembly and dismantling

The split inner case in which the rotating element is installed is positioned in a cylindrical outer barrel and requires only light bolting because the free space between the inner case and the outer barrel is exposed to discharge pressure, thereby sealing the precision surfaces at the split. As a result of surrounding the inner case with the pumped liquid, it is subjected to the same temperature as the rotating element, thereby permitting quick and uniform heating of the

entire unit. In addition to safety and efficiency, this construction also lends itself to accessibility without disturbing the suction and discharge pipe connection or driver. A complete rotating element can be done in the field for inspection of parts subject to wear, checking of clearances, etc. The Double Case Pump can also be put on line without preheating when necessary, and without the accompanying dangers of distortion and seizure.

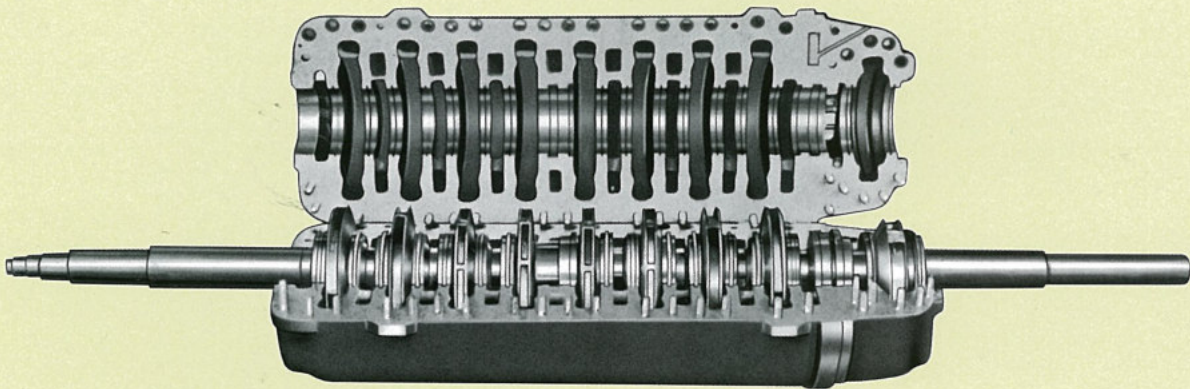

By the use of Double Volute inner cases, the flow is divided into two identical fluid channels in the plane of the impeller, with outlets 180° apart. Opposed forces of equal magnitude are created and radial balance without pressure-bending moment on the shaft, at any capacity, result. Due to exclusive staging and impeller arrangement, axial thrust without the use of balancing devices is eliminated. The inner case, by its Double Volute design, and the rotating element, by its staging arrangements, eliminates both axial and radial thrust.

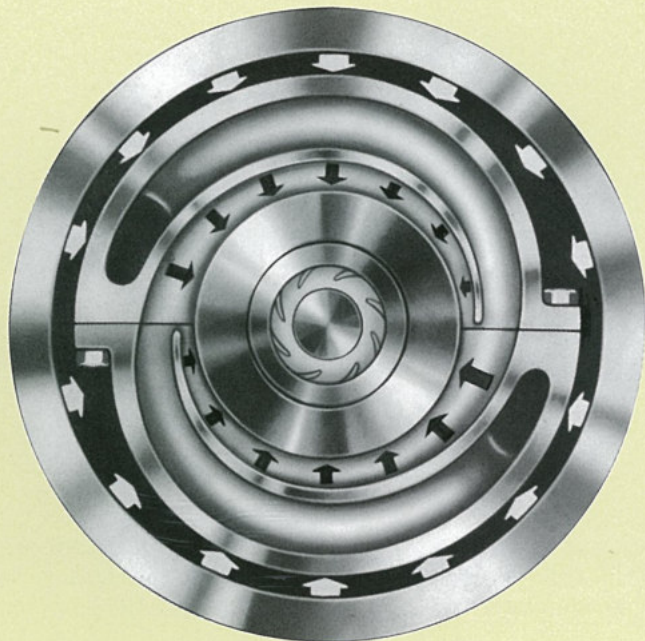

Design Features

The completely assembled rotating element consists only of impellers with their rings and the shaft. Materials of the same heat expansion co-efficient are used. Running clearances of the rotating element are maintained at all times regardless of the pumping temperature or of sudden changes therein.

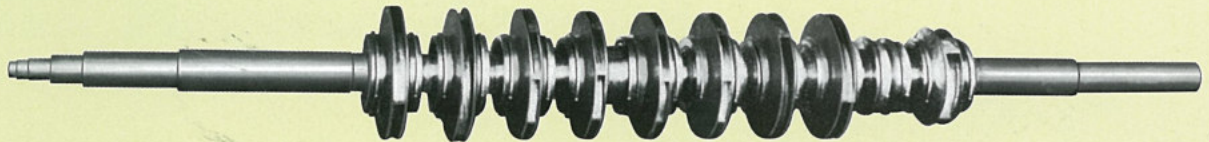

When internal inspection becomes necessary, the outer barrel cover is unbolted, the dismantling tray is attached, the inner cases pulled, upper half of the

case is raised and the completely assembled rotating element lifted from the case. The main piping and driver need not be disturbed.

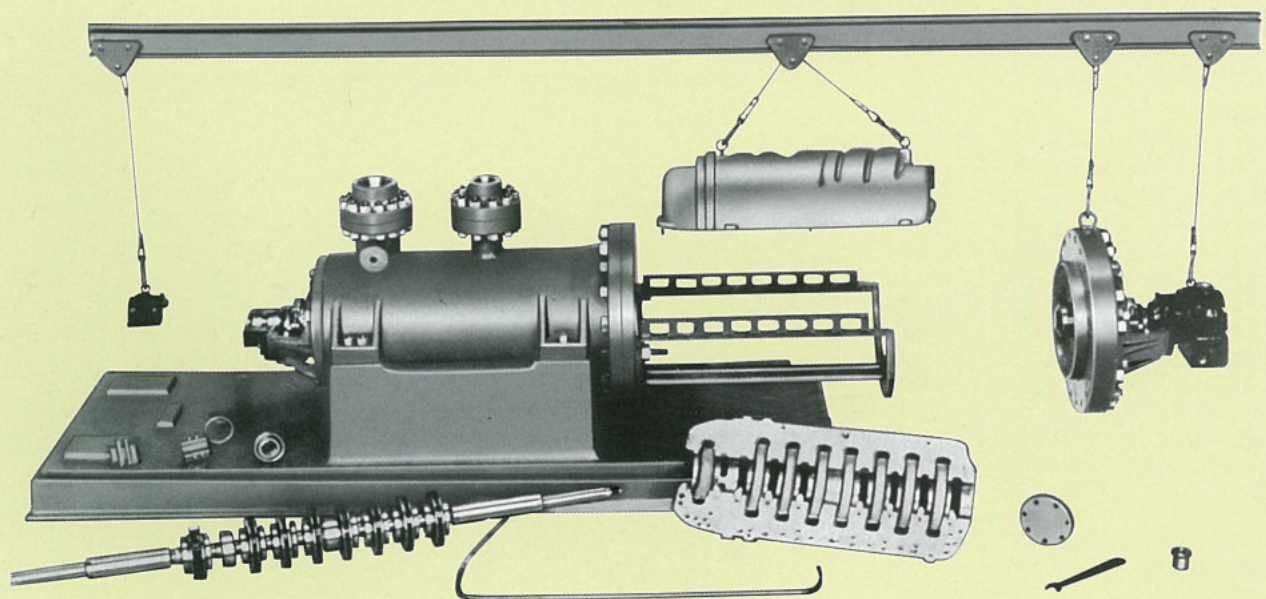

Production Facilities

Manufacturing

EBARA constantly maintains qualified procurement, sound fabrication, precise machining, stringent inspection, extensive testing, at every phase of pump design and manufacture. EBARA double case manufacturing facilities are located in Tokyo Japan.

Shown at right nozzle-to-barrel welding by qualified welder to approved procedures with weld integrity proven by strict NDT.

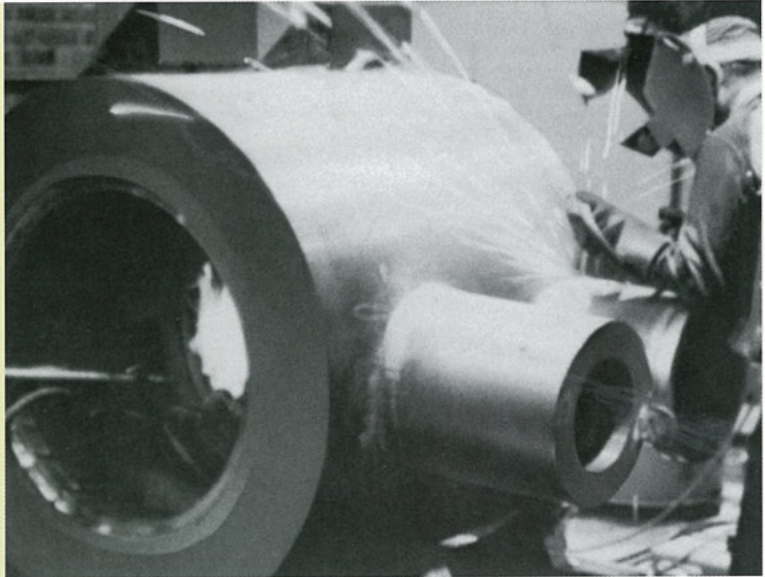

Testing

With our comprehensive program of non-destructive, hydrostatic, and performance testing, we know exactly how much pressure, temperature, and vibration Ebara pumps can take and how they react to severe temperature transients, loss of suction, and loss of shaft seal injection. Pump rotor dynamics, vibration, pressure pulsations, among the pump hydraulic characteristics, are carefully measured, recorded, and analyzed in our specialized test laboratories.

Shown at left is newest hot loop test facility

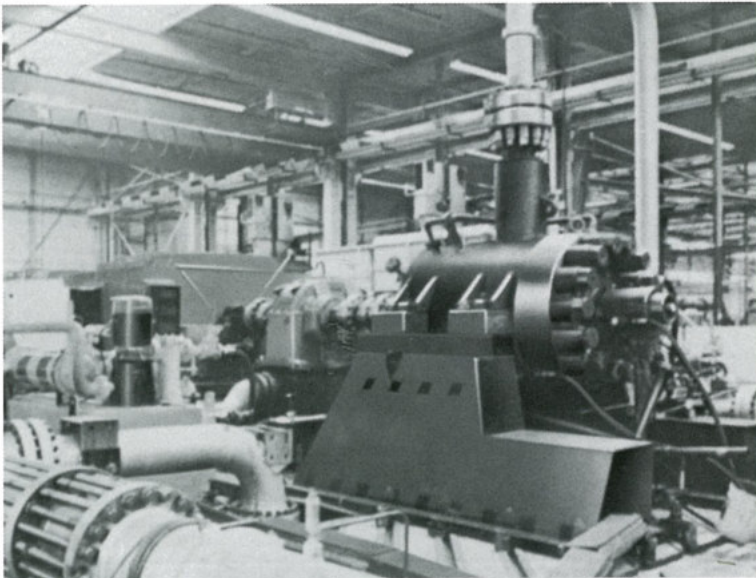

Installation

There are over 1000 Ebara double case high pressure pumps models HSB/HDB operating in the world. Earliest our double case boiler feed pump was installed in 1957 and till operating today.

Today's generation of our double case pumps in commercial operation in conventional fossil fueled power plants and modern combined power plants have ratings up to 1850t/h up to gauge 390kg/cm² {39MPa} discharge, up to 6000 min⁻¹ and up to 30,000kW. As generating power plants continue to increase in size and output, Ebara will continue to maintain a high degree of reliability in meeting the challenge of critical performance requirements.

Shown at right is 11600kW, 4500 min⁻¹, 1130t/h Gauge 29.9 MPa, capacity boiler feed pump.

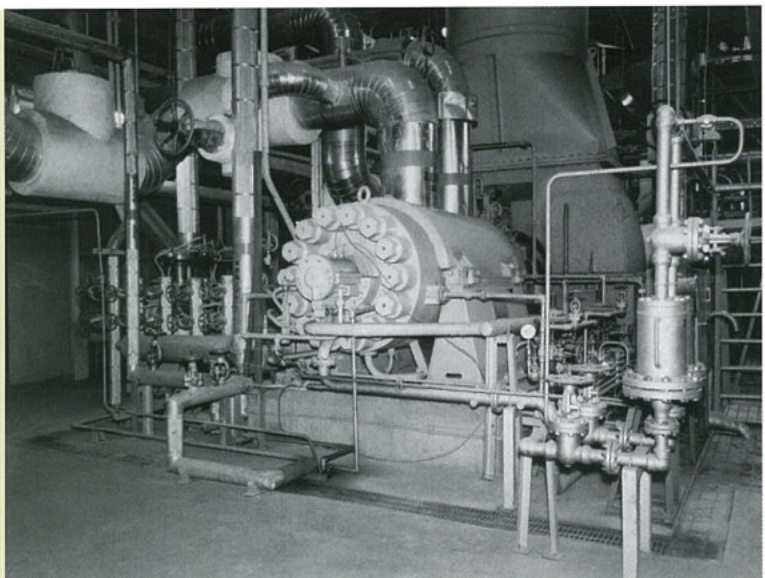

Quality Assurance

In order to satisfy user specifications and to conform with ASME Code and all other standards in the world, Ebara has established a consistent quality assurance system from the development stage to after-sales service on the basis of extensive technical data accumulated during many research projects and from results of actual operation.

Working and control practices are computerized to incorporate the correct quality level into each process from order reception to supply. Moreover, system such as inspector qualification, welder qualification, traceability, etc. have been established to make quality assurance a certainty.

New hydraulic parts designing and manufacturing system

All hydraulic parts of Ebara pumps including model HSB/HDB are designed and manufactured by Ebara new designing and manufacturing system. Our system is composed of a development & designing system with remote testing facilities, a production line and an integrated production control system. The development & designing system is based on a radically new designing concept of

inverse design method.

The hydraulic parts applied by new design are fabricated with new casting method and high-tech machining system to meet exact configuration of design.

1000 MW Super critical pressure boiler feed pump of thermal power plant.
Model: 16×16×18-5stg HDB
Capacities: 1740t/h
Discharge pressure: Gauge 30.4 MPa
Suction pressure: Gauge 1.48 MPa
Revolutions: 5250 min⁻¹
Turbine: 20000kW
Temperature: 155.1°C

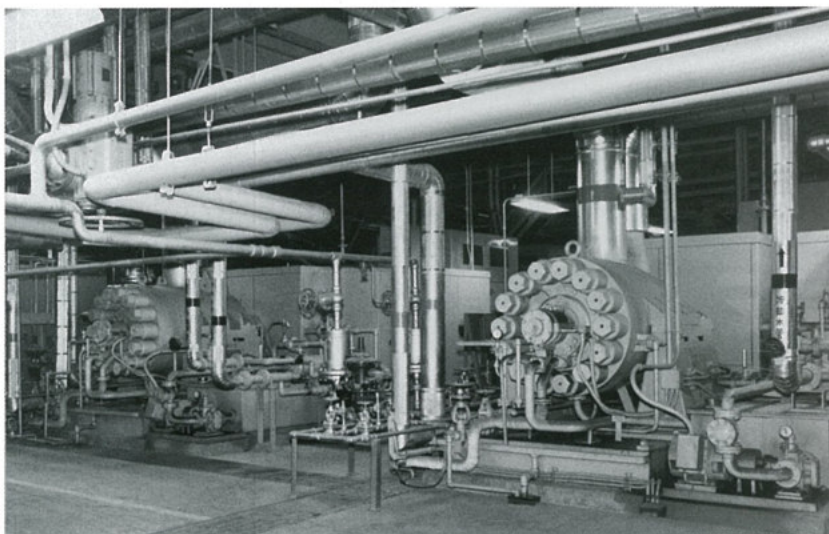
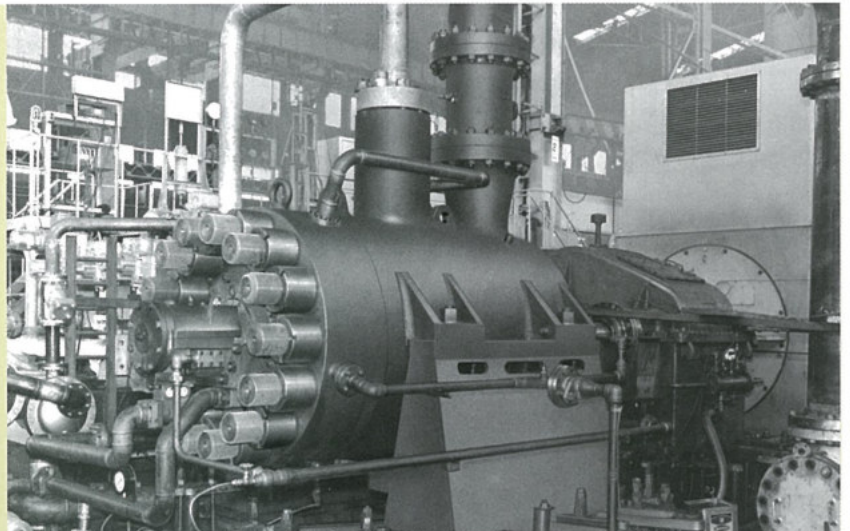

Boiler feed pump for thermal power plant
Model: 10×10×13-6stg HSB
Capacities: 565t/h
Discharge pressure: Gauge 30.5MPa
Suction pressure: Gauge 1.26MPa
Speed: 7100 min⁻¹
Motor: 6700kW
Temperature: 145.5°C



EBARA CORPORATION

Head Office:

11-1, Haneda Asahi-cho, Ohta-ku,
Tokyo, 144-8510 Japan
Phone: 81-3-3743-6111
Fax: 81-3-3745-3356
Internet homepage : <http://www.ebara.co.jp>

Sales headquarter:

1-6-27, Konan, Minato-ku, Tokyo,
108-8480, Japan
Phone: 81-3-5461-6101
Fax: 81-3-5976-0415

Please send your enquiries to the above International Division

○: Liaison Offices

■ AMERICA

UNITED STATES OF AMERICA

Ebara International Corporation (Sparks, NV)
Aircac, Inc. (Rochester, IN)
Elliott Turbomachinery Co., Inc. (Jeannette, PA)

BRAZIL

Ebara Indústrias Mecánicas e Comércio Ltda.
(Bauru, S.P.)

■ EUROPE

ENGLAND

Elliott Turbomachinery Limited (Basingstoke)

ITALY

- Italy Office (Vicenza)
- Ebara Pumps Europe S.p.A. (Trento)
- Sumoto S.r.l. (Vicenza)

SPAIN

Ebara Espana Bombas S.A. (Madrid)

■ ASIA

PEOPLE'S REPUBLIC OF CHINA

- Beijing Office (Beijing)
- Yantai Ebara Air Conditioning Equipment Co., Ltd.
(Yantai)
- Beijing Ebara Machinery Co., Ltd. (Beijing)
- Ebara Machinery (Shanghai) Co., Ltd. (Shanghai)
- Shanghai Ebara Engineering and Services Co., Ltd.
(Shanghai)
- Ebara Qingdao Co., Ltd. (Qingdao)
- Ebara Densan (Kunshan) Mfg. Co., Ltd. (Kunshan)

TAIWAN

- Taipei Office (Taipei)
- Ebara-Densan Taiwan Manufacturing Co., Ltd.
(Chung Li)
- Ebara-Elliott Service (Taiwan) Co., Ltd. (Taichung)
- Ebara Kailay Environmental Engineering Co., Ltd.
(Taipei)

KOREA

Hyosung-Ebara Co., Ltd. (Seoul)
Hyosung-Ebara Environment Engineering Co., Ltd.
(Seoul)

SINGAPORE

- Singapore Office (Singapore)
- Ebara Engineering Singapore Pte. Ltd.
(Singapore)

MALAYSIA

Ebara Pumps Malaysia Sdn. Bhd (Selangor)
Ebara Environmental Engineering (Malaysia) Sdn. Bhd.
(Selangor)

PHILIPPINES

- Manila Branch Office (Manila)
- Ebara Benguet, Inc. (Laguna)

VIETNAM

Ebara Hai Duong Company Ltd. (Hai Duong)
Ebara Vietnam Corporation (Hanoi)

THAILAND

- Bangkok Office (Bangkok)
- Ebara (Thailand) Limited (Bangkok)

INDIA

Kirloskar Ebara Pumps Limited (Pune)

■ MIDDLE-EAST

United Arab Emirates

- Middle East Office (Dubai)

■ OCEANIA

AUSTRALIA

Ebara Pumps Australia Pty. Ltd. (Bayswater, Vic)