



EBARA

PROCESS PUMP

Single Stage, Single Suction, Centerline Supported

CS1310E1

Model

UCW

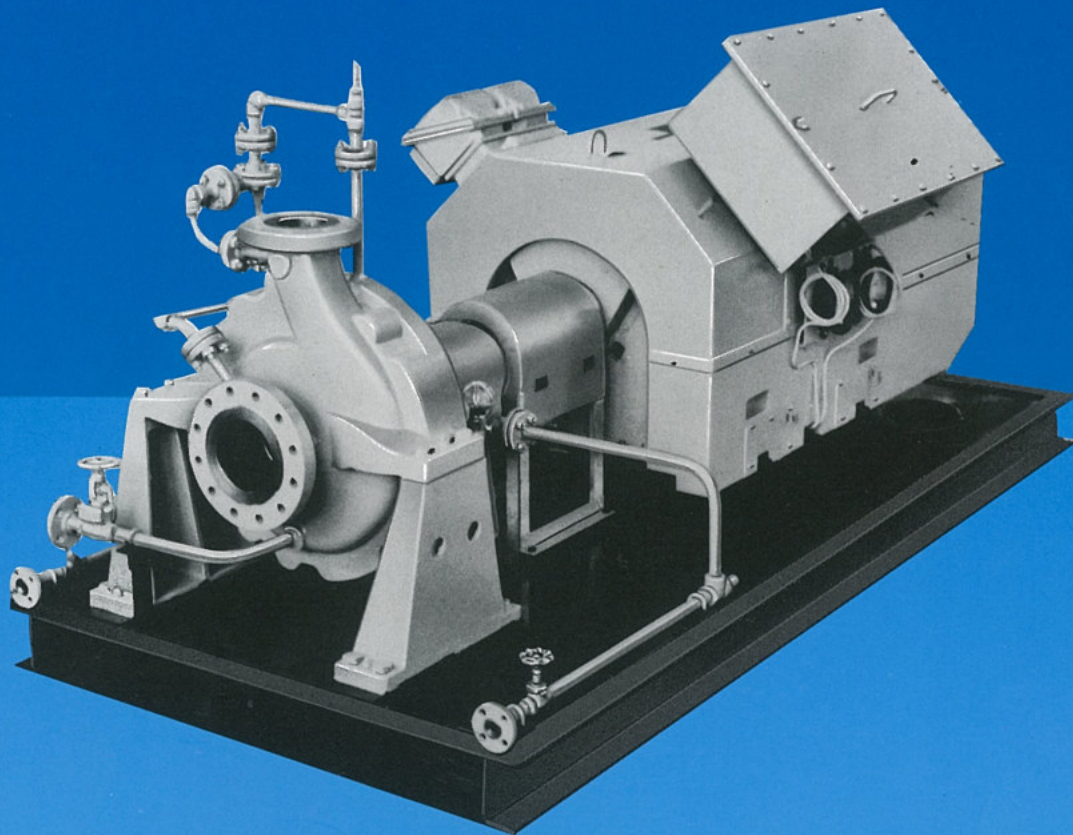

PROCESS PUMP

Single Stage, Single Suction, Centerline Supported

Model
UCW

API 610 **Beo**[®]

EBARA MODEL UCW PROCESS PUMPS of single stage, single suction, centerline supported, horizontal design have been widely used in petroleum refineries, the petrochemical industry and other chemical industries for the past few

years. Many improvements have been recently made on this pump to enhance its performance. Our modern tape controlled machines in conjunction with advanced quality control procedures insure that these pumps meet our high

manufacturing standards. Unique design of this high performance pump provides for superior and extended low-cost operation.

Applications

- Petroleum Refineries
- The Petrochemical Industry
- Other Chemical Industries

Ratings

Capacities	To 1920m ³ /h(8450 USGPM)
Heads	To 380 m (1250 ft)
Max. working pressures	Consistant with the pressure ratings of ANSI Class 300 flanges as a standard. Higher pressure ratings are available.
Rotation	Clockwise viewed from coupling end
Impeller	Enclosed
Temperatures	-100°C to 450°C (-150°F to 850°F)
Flanges	ANSI Class 300 as standard
Nozzles	End-Top/Top-Top
Stuffing box	Suitable for conventional packing & mechanical seal

Features

- Centerline supported heavy duty design.
- Back pull-out casing.
- Full compliance with API 610 specifications.
- All components have been designed for maximum parts interchangeability.
- Flexibility of design handles wide range of liquids.
- All sizes stocked for fast shipment.
- Low NPSH performance.

Designations

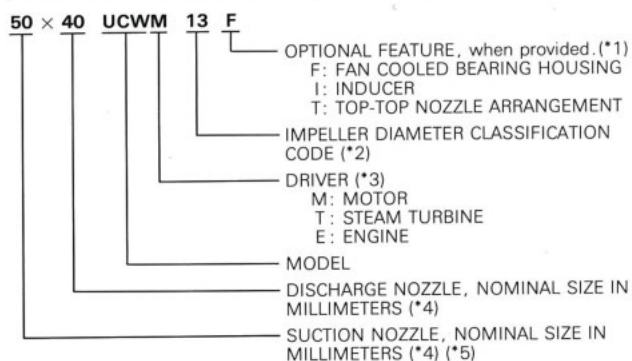

Notes:

- (*1) When two features are involved, the codes are in alphabetical order.
- (*2) The letters "Y" and "Z" following the impeller diameter classification code indicate different casing and impeller designs. To give an example, 150×100 UCWM 40, 150×100 UCWM 40Y and 150×100 UCWM 40Z have different casing and impeller designs from one another.
- (*3) When a step up or step down gear is provided, the code letter "G" is added between model and driver. For example, 150×100 UCWGM means that the pump is driven by an electric motor through a separate gear.
- (*4) When suction and discharge nozzles are identical, they shall not be duplicated, i.e. 200 UCWM 20 is the correct designation in lieu of 200×200 UCWM 20.
- (*5) When an inducer is provided a larger size nozzle is employed.

Construction

End-Top

Shaft Sealing: Mechanical seals are available from any mechanical seal maker. Alternately, a deep ring stuffing box with six rings of packing plus one lantern ring can be supplied.

Casing: The volute type casing is designed to maintain high efficiency over long periods of wear. The top centerline discharge connection makes the pump self venting.

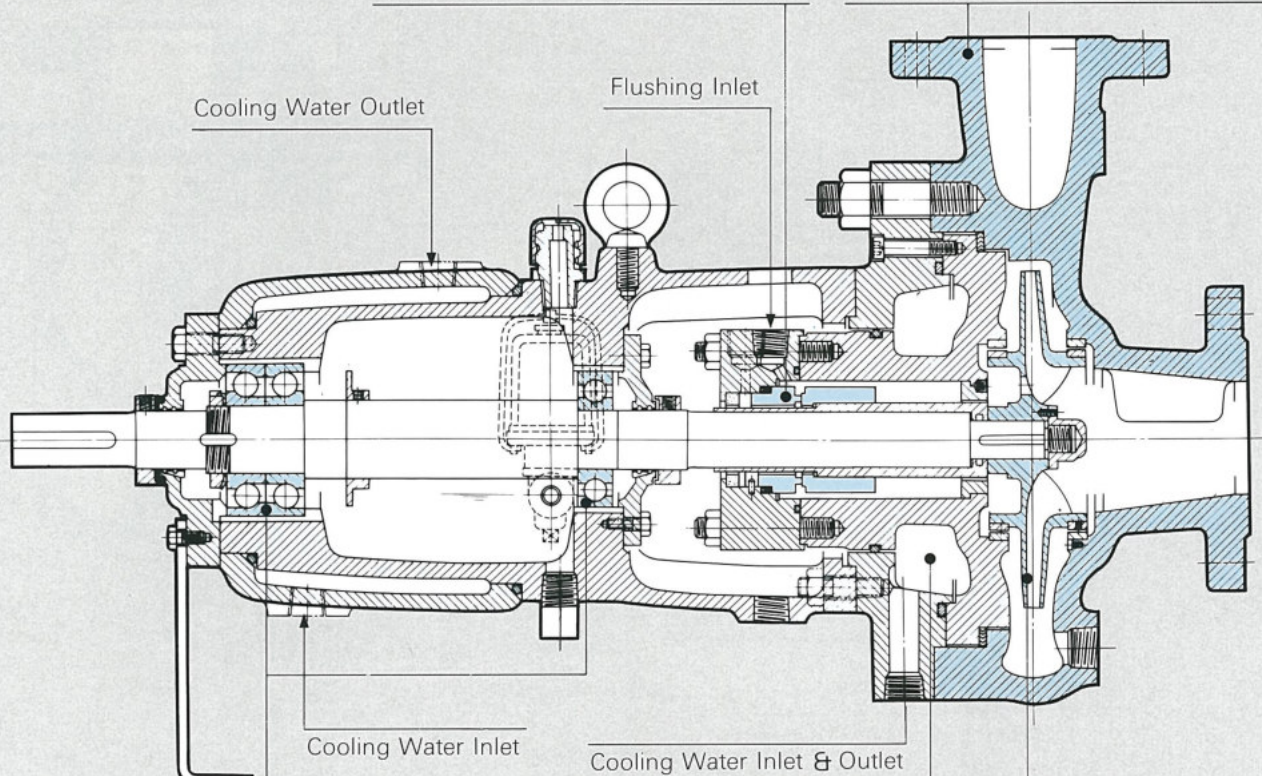

Bearings: Bearing housings are provided with single-row radial and dual single-row, back to back, angular contact thrust bearings. Standard lubrication system is an integral splash type with an oil flinger. Housing seals permit all weather operation.

Water Cooled Stuffing Box: A separate jacket type is illustrated. An integrated jacket type is also available.

Impeller: Enclosed impellers are designed for maximum efficiency and minimum required NPSH over a wide range of capacities. Balance holes minimize axial thrust. An inducer is available as an option.

Metallurgy

Part Name	Materials JIS / ASTM-AISI				
	C. Steel	C. Steel	12% Cr. Steel	304 S. Steel	316 S. Steel
Casing	SCPH2/A216WCB	SCPL1/A352LCB	SCS1/A743CA15	SCS13A/A743CF8	SCS14A/A743CF8M
Impeller	FC200/A48, CL. 30	SCS13A/A743CF8	SCS1/A743CA15	SCS13A/A743CF8	SCS14A/A743CF8M
Impeller Wear Ring	SUS420J2/AISI420	SUS304/AISI304	SUS420J2/AISI420	SUS304/AISI304	SUS316/AISI316
Shaft	S35C/AISI1035	SUS304/ANSI304	SUS420J1/AISI420	SUS304/AISI304	SUS316/AISI316
Case Wear Ring	FCD400/A536	SUS304/AISI304	SUS420J1/AISI420	SUS304/AISI304	SUS316/AISI316
Packing Sleeve	SUS420J2/AISI420	SUS304/AISI304	SUS420J2/AISI420	SUS304/AISI304	SUS316/AISI316
Mechanical Seal Sleeve	SUS420J2/AISI420	SUS304/AISI304	SUS420J2/AISI420	SUS304/AISI304	SUS316/AISI316

Notes: Following materials supplied on request: 304L S. Steel, 329J1 S. Steel, Hastelloy, 20 Alloy, Monel.

- Standard Materials
- Optional Materials

Construction

Top-Top

Shaft Sealing: Mechanical seals are available from any mechanical seal maker. Alternately a deep ring stuffing box with six rings of packing plus one lantern ring can be supplied.

Casing: The volute type casing is designed to maintain high efficiency over long periods of wear.

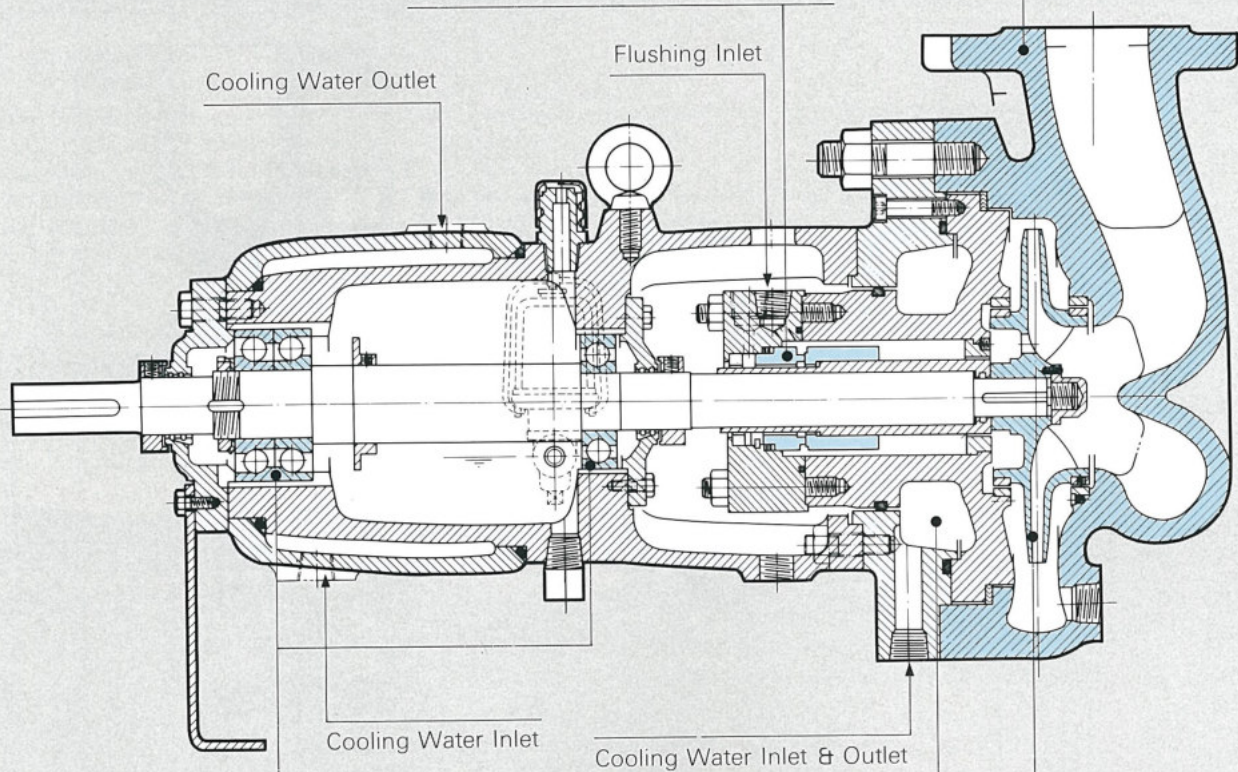

Water Cooled Stuffing Box: A separate, jacket type is illustrated. An integrated jacket type is also available.

Bearings: Bearing housings are provided with single-row radial and dual single-row, back to back, angular contact thrust bearings. Standard lubrication system is an integral splash type with an oil flinger. Housing seals permit all weather operation.

Impeller: Enclosed impellers are designed for maximum efficiency and minimum required NPSH over a wide range of capacities. Balance holes minimize axial thrust. An inducer is available as an option.

Metallurgy

Part Name	Materials JIS/ASTM-AISI				
	C. Steel	C. Steel	12% Cr. Steel	304 S. Steel	316 S. Steel
Casing	SCPH2/A216WCB	SCPL1/A352LCB	SCS1/A743CA15	SCS13A/A743CF8	SCS14A/A743CF8M
Impeller	FC200/A48, CL. 30	SCS13A/A743CF8	SCS1/A743CA15	SCS13A/A743CF8	SCS14A/A743CF8M
Impeller Wear Ring	SUS420J2/AISI420	SUS304/AISI304	SUS420J2/AISI420	SUS304/AISI304	SUS316/AISI316
Shaft	S35C/AISI1035	SUS304/AISI304	SUS420J1/AISI420	SUS304/AISI304	SUS316/AISI316
Case Wear Ring	FCD400/A536	SUS304/AISI304	SUS420J1/AISI420	SUS304/AISI304	SUS316/AISI316
Packing Sleeve	SUS420J2/AISI420	SUS304/AISI304	SUS420J2/AISI420	SUS304/AISI304	SUS316/AISI316
Mechanical Seal Sleeve	SUS420J2/AISI420	SUS304/AISI304	SUS420J2/AISI420	SUS304/AISI304	SUS316/AISI316

Notes: Following materials supplied on request: 304L S. Steel, 329J1S. Steel, Hastelloy, 20 Alloy, Monel.

Standard Materials
 Optional Materials

Optional Features

In order to accommodate your requests, the following features are available.

Inducer Arrangement
Oil Ring Lubricated Bearings
Oil Mist Lubricated Bearings
Water Cooled Bearing Housing / Separate Jacket Type

Water Cooled Bearing Housing / Integrated Jacket Type
Fan Cooled Bearing Housing
Water Cooled Stuffing Box / Separate Jacket Type
Water Cooled Stuffing Box / Integrated Jacket Type

Fan Cooled Bearing Housings

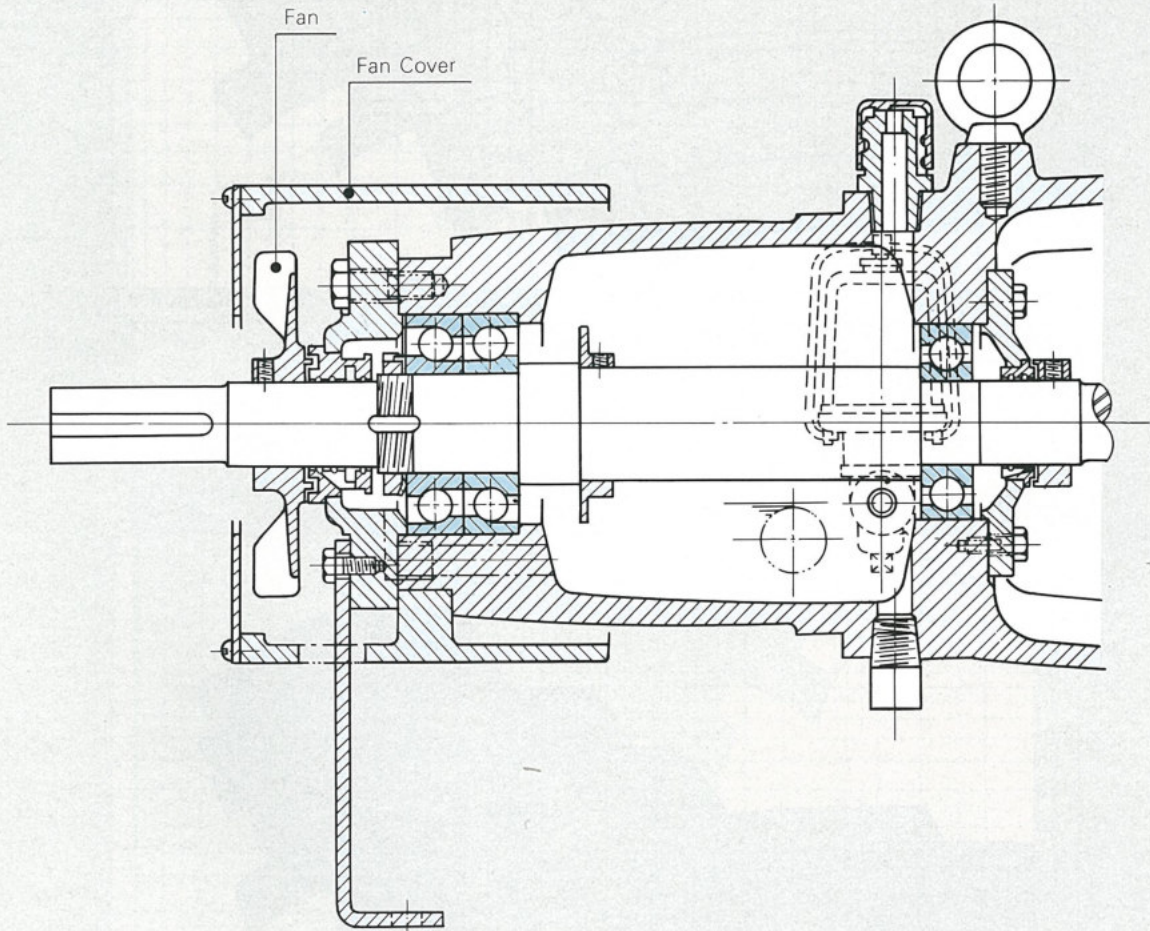

- The fan cooling system can be installed on both end-top and top-top nozzle pumps.
- The fan cooling system improves the operating temperature of the pump under severe conditions, without use of water.

Performance Ranges

50_{Hz}

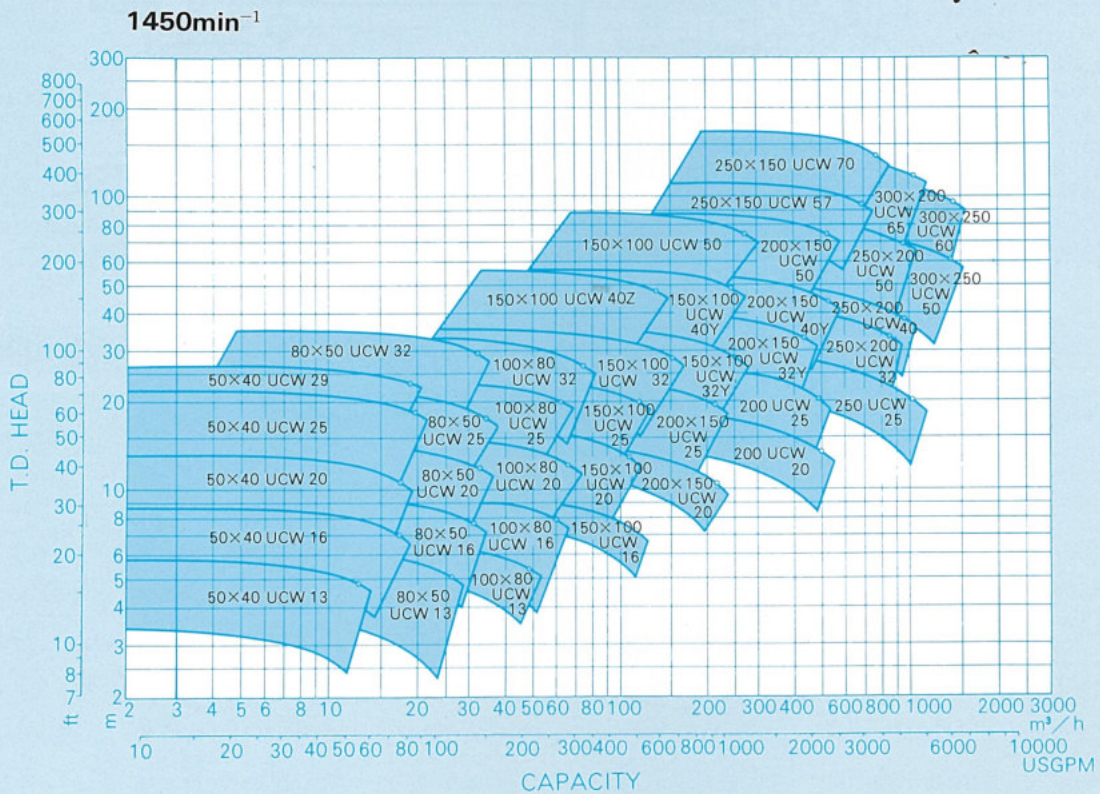
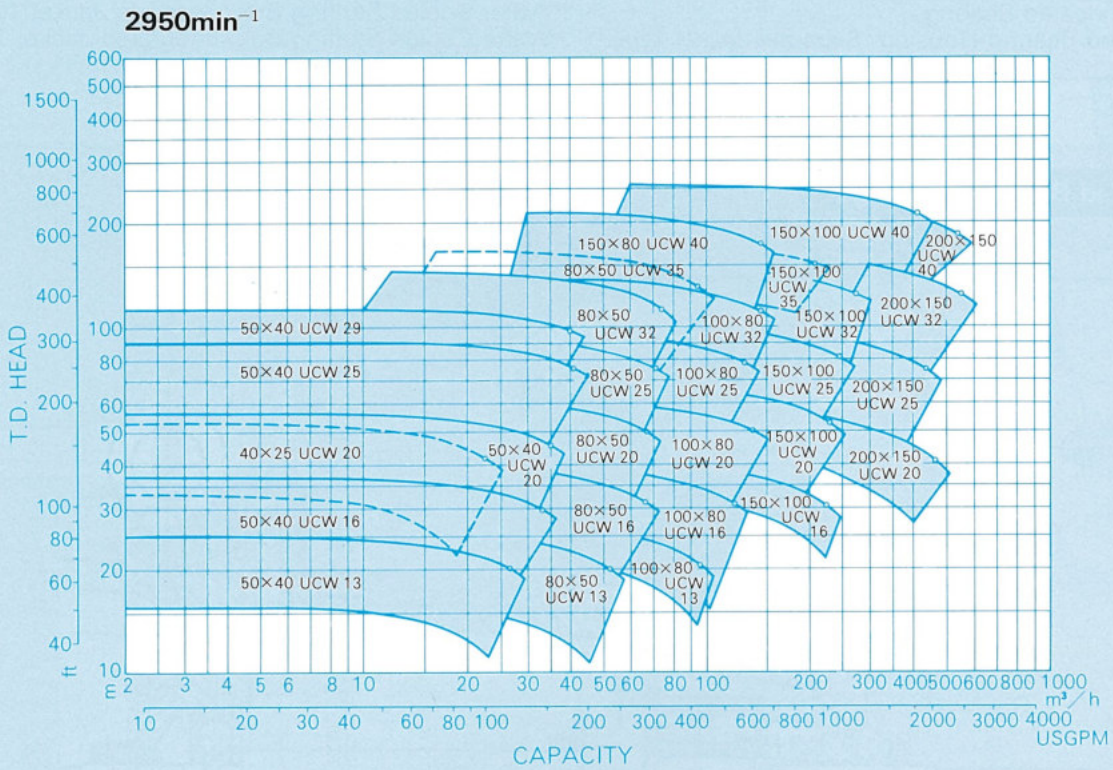

This selection chart is prepared for preliminary selection. Refer to individual performance curves for final selection. O denotes B.E.P. of the performance with an impeller of maximum diameter.

General Process Pumps

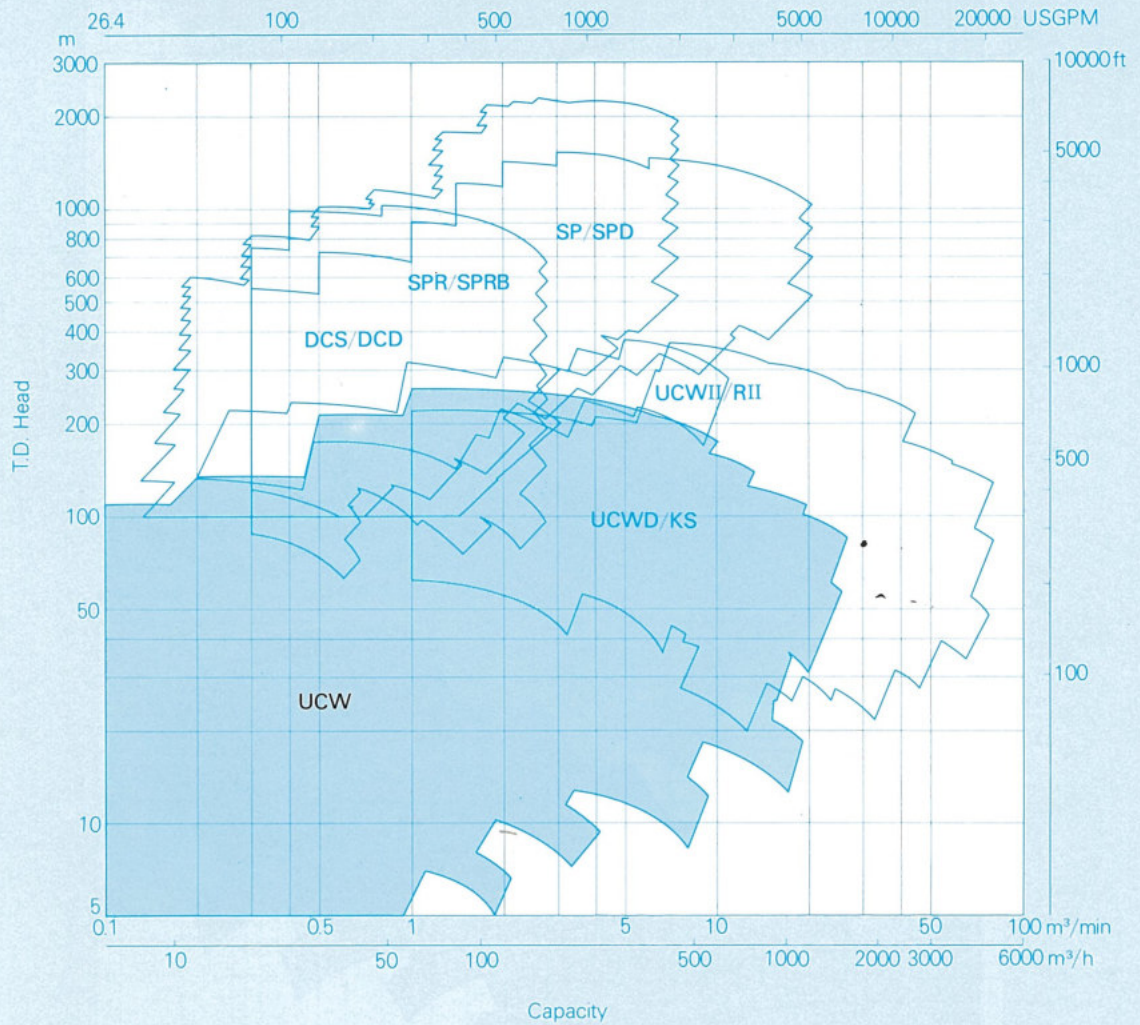

Performance ranges shown on these charts are for preliminary selection only.

Performance Ranges

60Hz

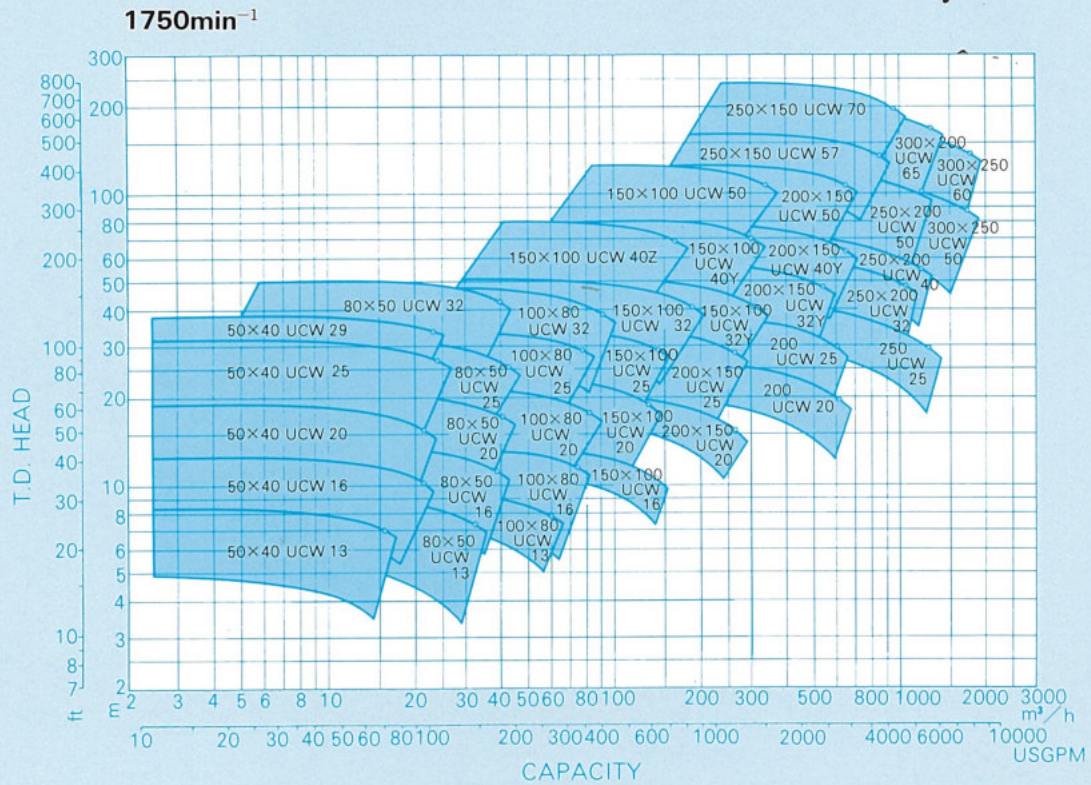
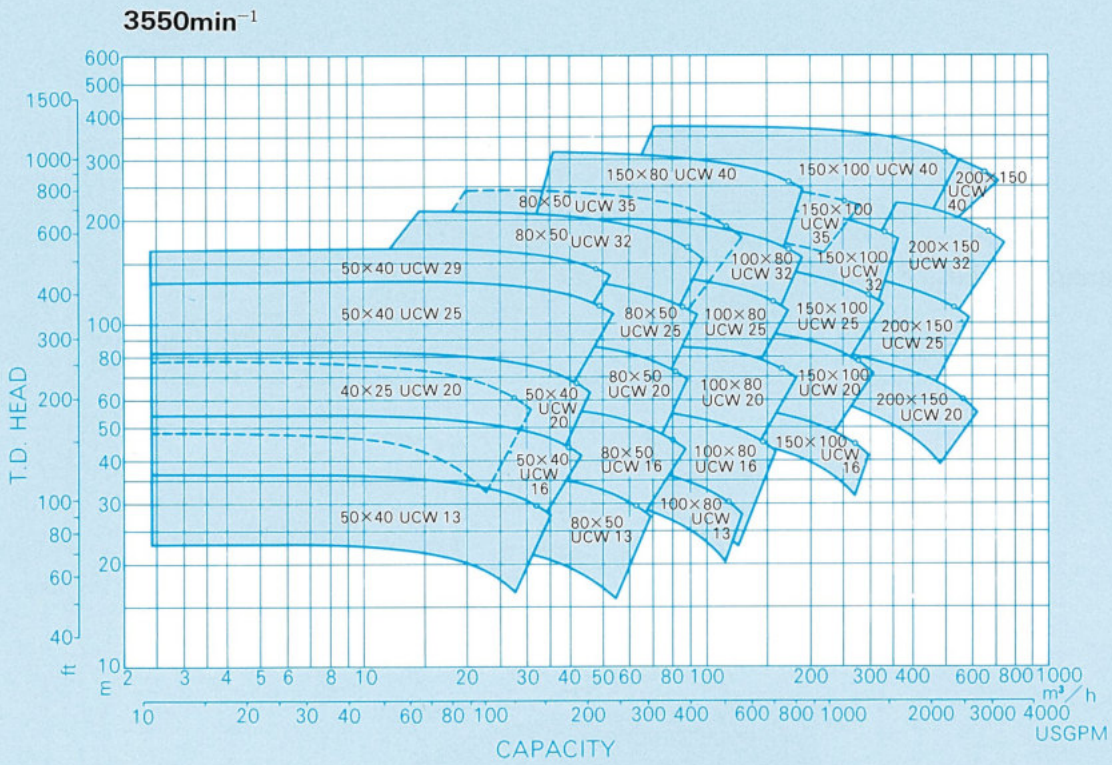

This selection chart is prepared for preliminary selection. Refer to Individual performance curves for final selection. O denotes B.E.P. of the performance with an impeller of maximum diameter.

General Process Pumps

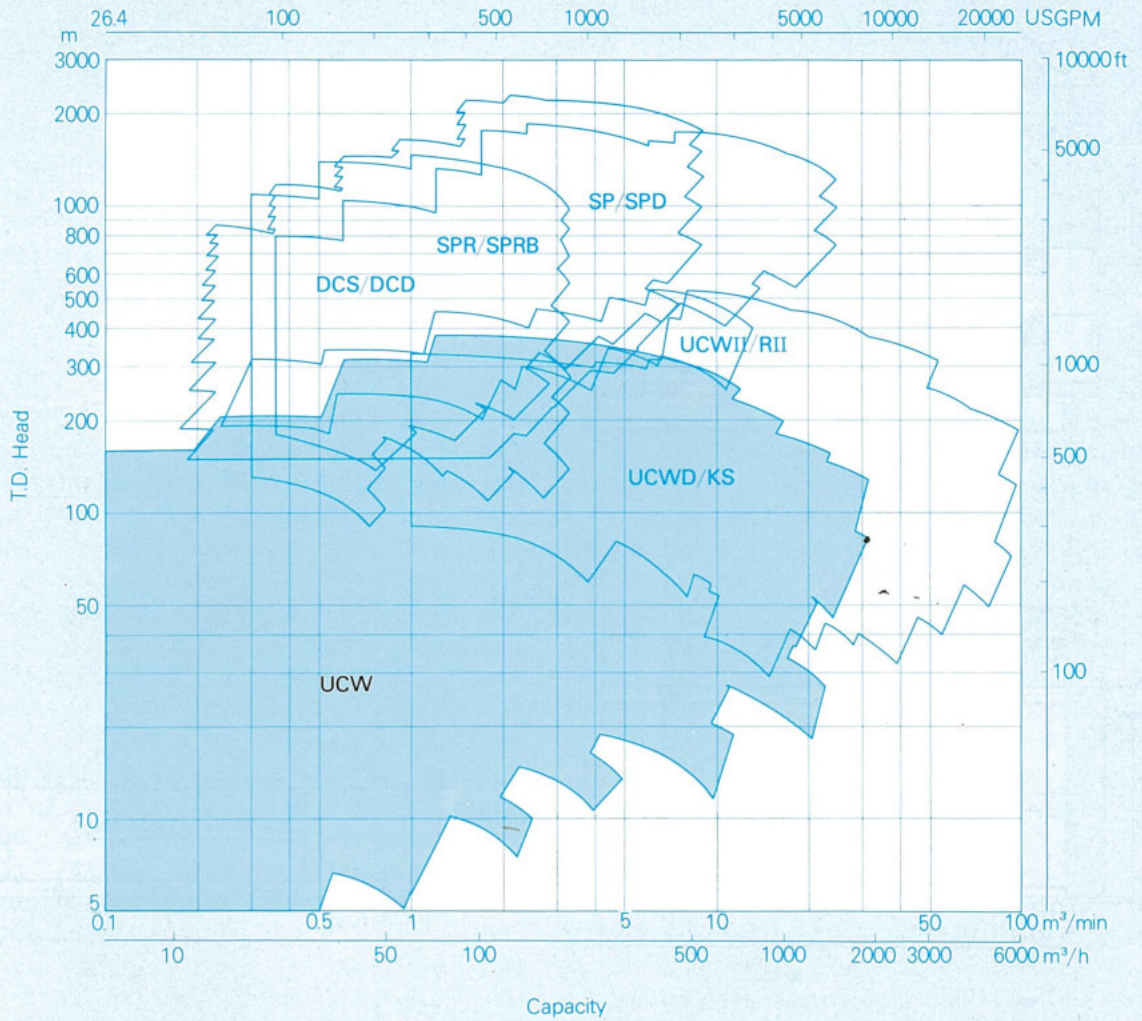

Performance ranges shown on these charts are for preliminary selection only.

End-Top

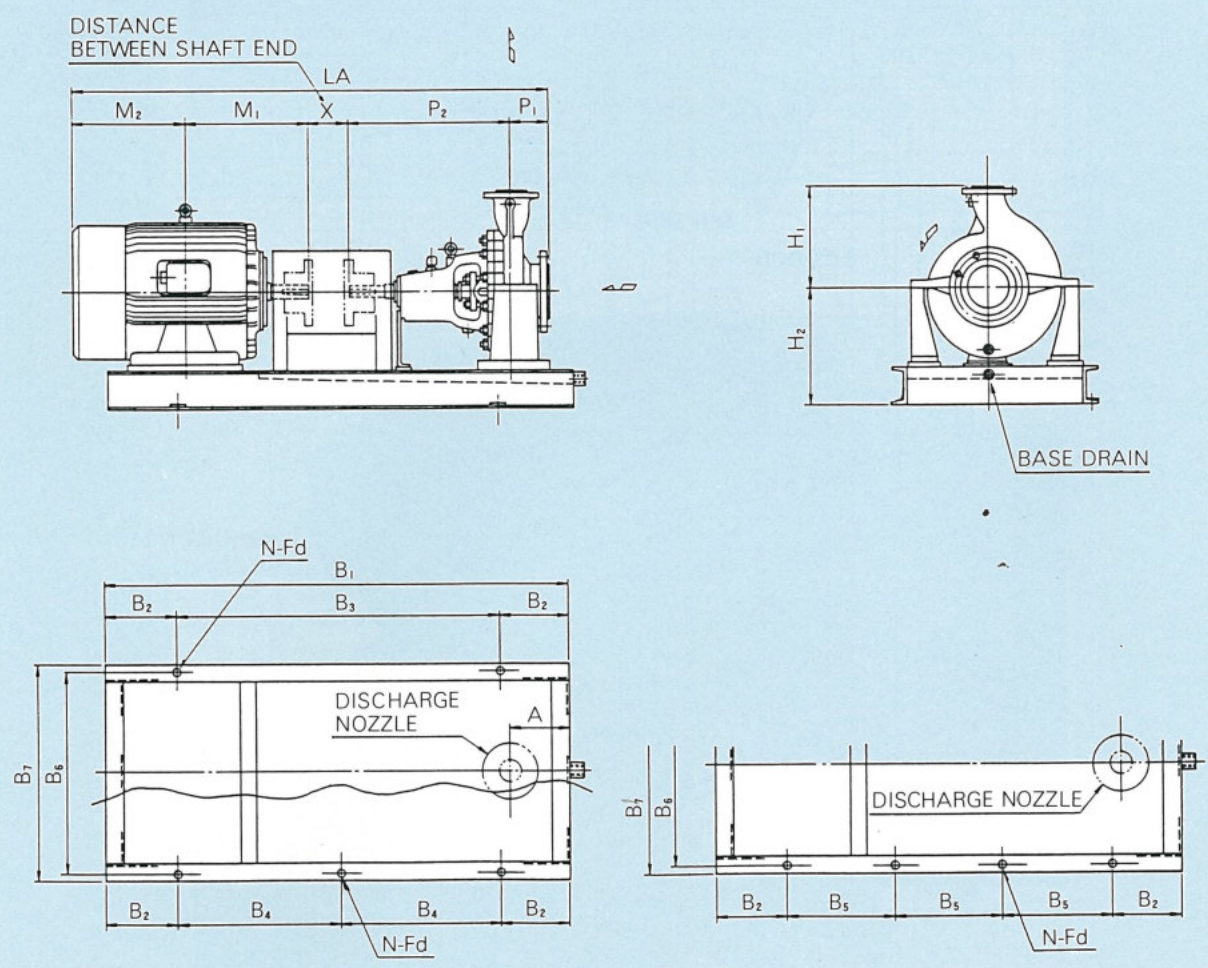

Dimensions

End-Top

PUMP SIZE	MOTOR		PUMP AND MOTOR (mm)								BASE PLATE (mm)										WEIGHT(kg)	
	KW	P ₁	P ₂	H ₁	H ₂	M ₁	M ₂	LA	X	A	B ₁	B ₂	B ₃	B ₄	B ₅	B ₆	B ₇	N	Fd	PUMP	BASE	
40x 25 20	22	120	580	240	341	370.5	531.5	1742	140	160	1460	185	1090	-	-	440	490	4	19	135	140	
50x 40 13	22	135	580	240	341	370.5	531.5	1757	140	160	1460	185	1090	-	-	440	490	4	19	139	140	
50x 40 16	22	135	580	240	341	370.5	531.5	1757	140	160	1460	185	1090	-	-	440	490	4	19	141	140	
50x 40 20	30	135	580	240	341	395.5	600.5	1851	140	165	1510	210	1090	-	-	440	490	4	19	141	165	
50x 40 25	55	140	650	275	425	452.5	600.5	1983	140	175	1680	210	1260	-	-	530	590	4	24	210	195	
50x 40 29	55	145	650	290	425	452.5	600.5	1988	140	175	1680	210	1260	-	-	530	590	4	24	222	195	
80x 50 13	22	140	580	240	341	370.5	574.5	1805	140	160	1460	185	1090	-	-	440	490	4	19	139	140	
80x 50 16	22	140	580	240	341	370.5	574.5	1805	140	160	1460	185	1090	-	-	440	490	4	19	139	140	
80x 50 20	30	150	580	240	341	395.5	600.5	1866	140	165	1510	210	1090	-	-	440	490	4	19	147	140	
80x 50 25	55	145	650	270	425	452.5	600.5	1988	140	175	1680	210	1260	-	-	530	590	4	24	214	195	
80x 50 32	110	170	730	310	430	509.5	545.5	2095	140	210	1890	245	1400	-	-	680	740	4	24	345	210	
100x 80 13	37	170	650	260	345	402	600.5	1962.5	140	145	1550	115	-	660	-	480	530	6	19	176	110	
100x 80 16	37	170	650	260	345	402	600.5	1962.5	140	145	1550	115	-	660	-	480	530	6	19	177	110	
100x 80 20	45	165	650	260	370	414.5	814.5	2184	140	145	1580	230	1120	-	-	490	550	4	24	182	135	
100x 80 25	90	165	730	300	430	509.5	545.5	2090	140	185	1870	235	1400	-	-	530	640	4	24	281	175	
100x 80 32	132	170	730	410	504	554.5	930.5	2525	140	245	2010	105	-	900	-	670	730	6	24	417	255	
150x 80 40	132	185	850	470	574	554.5	930.5	2700	180	265	2190	195	-	900	-	880	950	6	26	623	370	
150x100 16	55	190	650	295	425	452.5	930.5	2363	140	205	1710	225	1260	-	-	540	600	4	24	224	200	
150x100 20	132	185	730	340	470	554.5	930.5	2540	140	185	1950	275	1400	-	-	660	720	4	24	319	250	
150x100 25	132	185	730	340	470	554.5	930.5	2540	140	185	1950	275	1400	-	-	660	720	4	24	363	250	
150x100 32	132	195	730	450	574	554.5	930.5	2590	180	230	2050	125	-	900	-	880	950	6	26	562	355	
150x100 32Y	55	200	730	370	529	452.5	930.5	2493	180	260	1880	230	-	710	-	850	920	6	26	600	330	
150x100 40	132	200	850	575	624	554.5	930.5	2735	200	295	2240	220	-	900	-	1020	1090	6	26	774	420	
150x100 40Y	90	205	730	420	529	539.5	575	2229.5	180	255	2000	150	-	850	-	890	960	6	26	696	365	
150x100 40Z	55	200	730	370	529	452.5	930.5	2493	180	260	1880	230	-	710	-	850	920	6	26	700	330	
150x100 50	132	215	850	460	574	614.5	620.5	2480	180	270	2260	230	-	900	-	930	1000	6	26	1090	400	
200 20	55	250	765	430	529	482.5	495	2192.5	200	245	1950	275	1400	-	-	850	920	4	26	700	315	
200 25	75	220	765	480	529	514	515	2194	180	260	2000	300	1400	-	-	900	970	4	26	765	380	
200x150 20	132	220	745	380	529	554.5	930.5	2650	200	260	2100	150	-	900	-	710	780	6	26	404	315	
200x150 25	132	220	760	450	529	554.5	930.5	2665	200	260	2120	160	-	900	-	770	840	6	26	512	315	
200x150 32	132	220	850	450	529	554.5	930.5	2755	200	260	2210	205	-	900	-	770	840	6	26	559	335	
200x150 32Y	132	230	760	480	529	614.5	620.5	2405	180	260	2160	180	-	900	-	910	980	6	26	876	345	
200x150 40	132	230	850	525	624	554.5	930.5	2765	200	285	2230	215	-	900	-	930	1000	6	26	834	410	
200x150 40Y	132	230	760	480	529	614.5	620.5	2405	180	260	2160	180	-	900	-	910	980	6	26	881	345	
200x150 50	132	245	950	580	574	614.5	620.5	2610	180	306	2380	195	-	1000	-	1180	1250	6	26	1510	450	
250 25	132	280	785	580	574	614.5	620.5	2500	200	290	2230	215	-	900	-	1190	1260	6	26	860	450	
250x200 32	132	255	850	580	574	614.5	620.5	2540	200	290	2300	150	-	1000	-	1140	1210	6	28	1040	450	
250x200 40	132	255	850	580	574	614.5	620.5	2540	200	290	2300	150	-	1000	-	1140	1210	6	26	1050	450	
250x200 50	110	250	950	650	624	589	575	2554	200	335	2390	195	-	1000	-	1230	1300	6	26	1790	485	
250x150 57	140	250	1110	650	300	741	1078	3459	280	370	3040	245	-	-	850	1200	1280	8	28	1900	600	
250x150 70	280	270	1200	780	860	874	1271	3915	300	445	3400	275	-	-	950	1350	1440	8	28	2100	850	
300x250 50	280	300	1135	700	800	874	1271	3860	280	380	3330	225	-	-	950	1360	1440	8	28	2100	900	
300x250 60	450	300	1200	750	815	1095	1593	4480	300	400	3650	355	-	-	980	1360	1440	8	28	2300	1100	
300x200 65	350	280	1190	750	860	914	1330	4014	300	440	3440	295	-	-	950	1420	1500	8	28	2200	950	

Note: Dimensions are in mm and for guidance only.

Certified drawings will be provided in all cases of actual construction. Motor dimensions are for a given IEC frame.

Base-plates are sized per our standard, not per the standard base plates in Appendix H of API 610.

On providing on inducer and / or a fan Cooled bearing housing, the certain dimensions differ from those in dicated in the above list.

Dimensions

Top-Top

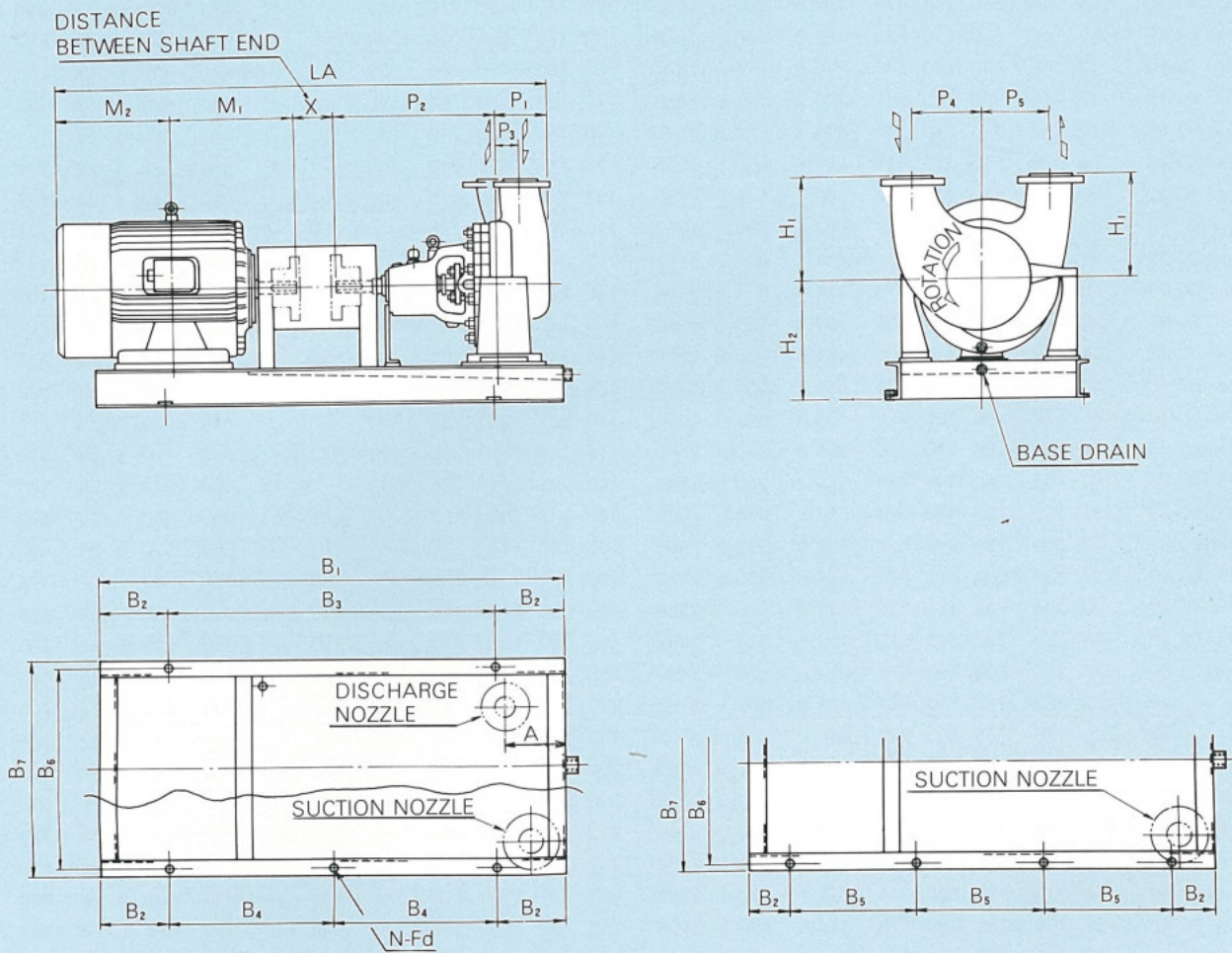

Dimensions

Top-Top

PUMP SIZE	MOTOR		PUMP AND MOTOR (mm)											BASE PLATE (mm)										WEIGHT(kg)	
	KW	P ₁	P ₂	P ₃	P ₄	P ₅	H ₁	H ₂	M ₁	M ₂	LA	X	A	B ₁	B ₂	B ₃	B ₄	B ₅	B ₆	B ₇	N	Fd	PUMP	BASE	
40x 25 20T	22	100	580	25	80	110	230	341	370.5	531.5	1722	140	160	1460	185	1090	-	-	440	490	4	19	140	140	
50x 40 13T	22	113	580	30	90	100	210	341	370.5	531.5	1735	140	160	1460	185	1090	-	-	440	490	4	19	145	140	
50x 40 16T	22	113	580	30	90	100	210	341	370.5	531.5	1735	140	160	1460	185	1090	-	-	440	490	4	19	150	140	
50x 40 20T	30	117	580	30	80	100	230	341	395.5	600.5	1833	140	185	1510	210	1090	-	-	440	490	4	19	150	165	
50x 40 25T	55	125	650	30	80	140	260	425	452.5	600.5	1969	140	175	1680	210	1260	-	-	530	590	4	24	220	195	
50x 40 29T	55	127	650	30	80	155	270	425	452.5	600.5	1970	140	175	1680	210	1260	-	-	530	590	4	24	235	195	
80x 50 13T	22	128	580	30	115	110	230	341	370.5	574.5	1793	140	160	1460	185	1090	-	-	440	490	4	19	145	140	
80x 50 16T	22	128	580	30	115	110	230	341	370.5	574.5	1793	140	160	1460	185	1090	-	-	440	490	4	19	145	140	
80x 50 20T	30	141	580	30	105	120	240	341	395.5	600.5	1857	140	165	1510	210	1090	-	-	440	490	4	19	155	140	
80x 50 25T	55	138	650	40	90	145	260	425	452.5	600.5	1981	140	175	1680	210	1260	-	-	530	590	4	24	225	195	
80x 50 32T	110	147	730	40	80	185	350	430	509.5	545.5	2072	140	210	1890	245	1400	-	-	680	740	4	24	360	210	
100x 80 13T	37	160	650	60	150	120	260	345	402	600.5	1952.5	140	145	1550	115	-	660	-	480	530	6	19	185	110	
100x 80 16T	37	160	650	60	150	120	260	345	402	600.5	1952.5	140	145	1550	115	-	660	-	480	530	6	19	185	110	
100x 80 20T	45	164	650	50	130	135	250	370	414.5	814.5	2183	140	145	1580	230	1120	-	-	490	550	4	24	190	135	
100x 80 25T	90	173	730	50	120	160	280	430	509.5	545.5	2098	140	185	1870	235	1400	-	-	580	640	4	24	295	175	
100x 80 32T	132	177	730	50	90	195	350	504	554.5	930.5	2532	140	275	2010	105	-	900	-	670	730	6	24	430	255	
150x 80 40T	40	195	850	40	110	240	450	574	554.5	930.5	2710	180	265	2190	195	-	900	-	880	950	6	25	640	370	
150x100 16T	55	218	650	90	200	145	320	425	452.5	930.5	2391	140	205	1710	225	1260	-	-	540	600	4	24	240	200	
150x100 20T	132	203	730	70	170	185	330	470	554.5	930.5	2558	140	185	1950	275	1400	-	-	660	720	4	24	340	250	
150x100 25T	132	203	730	70	170	185	330	470	554.5	930.5	2558	140	185	1950	275	-	-	-	660	720	4	24	380	250	
150x100 32T	132	207	730	60	150	210	420	572	554.5	930.5	2602	180	280	2050	125	-	900	-	880	950	6	26	585	355	
150x100 32YT	55	256	730	80	105	220	355	529	452.5	930.5	2549	180	260	1880	230	-	710	-	850	920	6	26	625	330	
150x100 40T	132	238	850	60	95	270	500	624	554.5	930.5	2773	200	295	2240	220	-	900	-	1020	1090	6	26	805	420	
150x100 40YT	90	251	730	110	105	245	400	529	539.5	575	2275.5	180	255	2000	150	-	850	-	890	960	6	26	720	365	
150x100 40ZT	55	214	730	70	105	235	370	529	452.5	930.5	2507	180	260	1880	230	-	710	-	850	920	6	26	725	330	
150x100 50T	132	256	850	110	115	290	430	574	614.5	620.5	2521	180	270	2260	220	1400	900	-	930	1000	6	26	1110	400	
200 20T	55	300	765	160	190	240	380	529	482.5	495	2242.5	200	245	1950	275	1400	-	-	850	920	4	26	730	315	
200 25T	75	282	765	140	190	260	400	529	514	515	2256	180	260	2000	300	-	-	-	900	970	4	28	800	380	
200x150 20T	132	238	745	110	220	195	370	529	554.5	930.5	2668	200	260	2100	150	-	900	-	710	780	6	26	430	315	
200x150 25T	132	245	760	90	190	240	400	529	554.5	930.5	2690	200	260	2120	160	-	900	-	770	840	6	26	545	315	
200x150 32T	132	245	850	90	190	240	400	529	554.5	930.5	2780	200	260	2210	205	-	900	-	770	840	6	26	585	335	
200x150 32YT	132	395	760	120	140	275	450	529	614.5	620.5	2570	180	260	2160	180	-	900	-	910	980	6	26	910	345	
200x150 40T	132	257	850	100	155	265	500	624	554.5	930.5	2792	200	285	2230	215	-	900	-	930	1000	6	26	870	410	
200x150 40YT	132	395	760	120	140	275	450	529	614.5	620.5	2570	180	260	2160	180	-	900	-	910	980	6	26	910	345	
200x150 50T	132	312	950	100	120	320	500	574	614.5	620.5	2677	180	305	2390	195	-	1000	-	1180	1250	6	26	1540	450	
250 25T	132	354	785	180	195	310	450	574	614.5	620.5	2574	200	280	2230	215	-	900	-	1230	1300	6	26	940	470	
250x200 32T	132	344	850	185	160	310	560	574	614.5	620.5	2629	200	290	2300	150	-	1000	-	1180	1250	6	26	1090	470	
250x200 40T	132	344	850	185	160	310	560	574	614.5	620.5	2629	200	290	2300	150	-	1000	-	1180	1250	6	25	1100	470	
250x200 50T	110	364	950	160	160	355	610	624	689	575	2678	200	335	2390	195	-	1000	-	1270	1340	6	26	1840	500	
250x150 57T	140	342	1110	140	130	365	570	800	741	1078	3551	280	370	3040	245	-	-	850	1240	1320	8	28	1950	880	
250x150 70T	280	360	1200	140	120	450	680	860	874	1271	4005	300	445	3400	275	-	-	950	1400	1480	8	28	2150	930	
300x250 50T	230	410	1135	160	180	410	620	800	874	1271	3970	280	380	3300	225	-	-	950	1400	1480	8	28	2150	1200	
300x250 60T	450	376	1200	180	150	425	640	815	1095	1593	4564	300	400	3650	355	-	-	980	1400	1480	8	28	2360	980	
300x200 65T	350	364	1190	150	150	430	660	860	914	1330	4098	300	440	3440	295	-	-	950	1460	1540	8	28	2250	980	

Note: Dimensions are in mm and for guidance only.
 Certified drawings will be provided in all cases of actual construction. Motor dimensions are for a given IEC frame.
 Base-plates are sized per our standard, not per the standard base plates in Appendix H of API 610.
 On providing a fan Cooled bearing housing, the certain dimensions differ from those indicated in the above list.

Guides to Selecting Centerline Supported Type Process Pumps

Centerline Supported Pumps Offer The Following Advantages

Use of a spacer type coupling permits pump disassembly without removal of prime mover or piping.

Centerline supported effectively reduces any thermal expansion or contraction of pump components. Centerline supported provides full support for any pipe loading. When selecting an Ebara centerline supported process pump with the aforementioned foregoing features, choose the model best suited to your needs by referring to the performance ranges.

Description of Models:

Model UCWD

Open side, horizontal, single stage, double suction centerline supported type.

Nominal diameter: 150~200mm
T.P. (gauge) 50kgf/cm²{4.90 MPa}
79kgf/cm²{7.74 MPa}

Model KS

Closed side, horizontal, single stage, double suction centerline supported type.

Nominal diameter: 150~700mm
T.P. (gauge) 50kgf/cm²{4.90 MPa}
79kgf/cm²{7.74 MPa}

Model UCW II

Two stage, single suction, centrifugal pump.
Centerline supported, closed impeller, single axial thrust support.
Nominal diameter: 50~100mm
T.P. (gauge) 50kgf/cm²{4.90 MPa}
79kgf/cm²{7.74 MPa}

Model R II

Two stage, single suction, centrifugal pump.
Centerline supported, closed impeller, double axial thrust support.
Nominal diameter: 80~150mm
T.P. (gauge) 75kgf/cm²{7.35 MPa}
112kgf/cm²{10.98 MPa}

Model SPR • SPRB

Horizontal multistage pump of single case, axially split diffuser and centerline supported type.
Nominal diameter: 80~150mm
T.P. (gauge) 150kgf/cm²{14.7 MPa}
225kgf/cm²{22.0 MPa}

Model SP • SPD

Horizontal multistage pump of single case, axially split volute and centerline supported type.
Nominal diameter: 80~300mm
T.P. (gauge) 200kgf/cm²{19.6 MPa}
300kgf/cm²{29.4 MPa}

Model DCS • DCD

Horizontal double case pump of multistage, ring section inner casing, diffuser type.
Nominal diameter: 50~250mm
T.P. (gauge) 210kgf/cm²{20.6 MPa}
315kgf/cm²{30.9 MPa}

Selection of Shaft Seal Unit

The shaft seal unit is one of the most important components of the process pump, and thus full attention should be given to its selection.

A mechanical seal should be used for minimizing leaks or when a very high suction pressure (about 10kgf/cm²{0.98 MPa} (gauge) or higher) is involved.

You are requested to indicate the desired model of mechanical seal. In case the desired model cannot be indicated, the following particulars should be given: Name and properties of liquid to be handled, vapor pressure particularly at the working temperature, specific gravity, presence of slurry and coagulability, viscosity, inflammability, etc. A proper mechanical seal will be selected and mounted by Ebara.

Inquires for Ebara Process Pumps

In submitting inquiries, the following data are requested:

- 1 Discharge rate, total head, suction pressure, Av. NPSH
- 2 Liquid to be handled:
Name of liquid, composition,

temperature, specific gravity, viscosity, vapor pressure, presence of corrosive and abrasive action
presence of solid content.

3

Any desires regarding the material of parts contacting the liquid and type of construction of gland.

4

Type of prime mover (if electric motor is desired, indicate frequency and voltage).

5

Applicable standards.

6

Any other requirements.

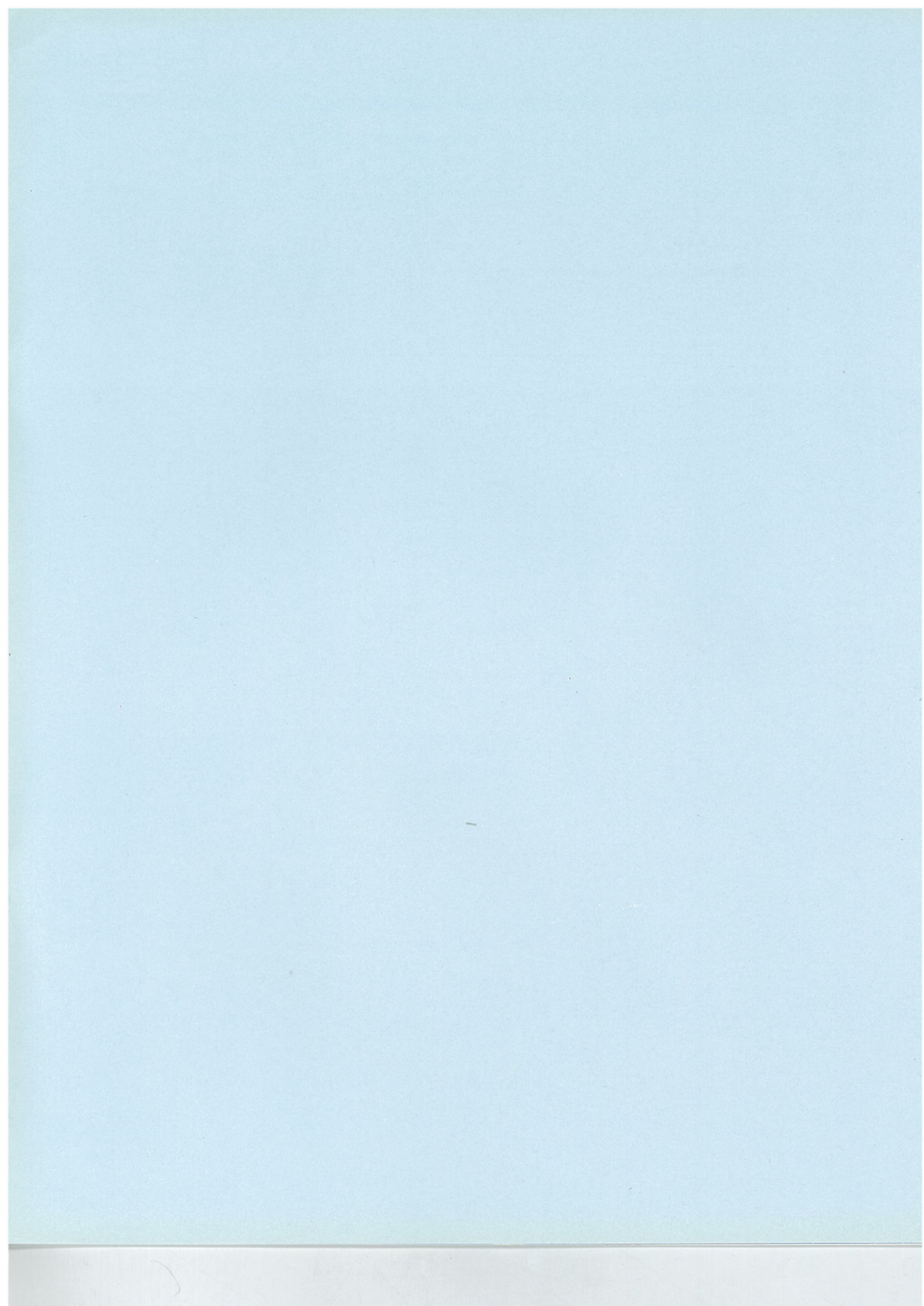



EBARA CORPORATION

Head Office:
11-1, Haneda Asahi-cho, Ota-ku,
Tokyo, 144 Japan
Phone: Tokyo 3743-6111
Cable: EBARAMAIN TOKYO
Int'l Telex: J22988 EBARA TYO
Fax: Tokyo 3745-3356

International Division:
Asahi Bldg., 6-7, Ginza 6-chome, Chuo-ku,
Tokyo, 104 Japan
Phone: Tokyo 3289-6111
Cable: EBARACO TOKYO
Int'l Telex: J26976 TOEBARA
Fax: Tokyo 3574-7080

Please send your enquiries to the above International Division

- Liaison Offices
 Subsidiary Companies or J/V

■ AMERICA

UNITED STATES OF AMERICA

- EBARA America Corporation**
Foster City (San Francisco Area), CA.
- EBARA International Corporation**
Head Office: Sparks (Reno area), NV.
Offices: Houston, TX.
Charlotte, NC.
N. Kansas City, MO.
London, U.K.
- EBARA Technologies Incorporated**
Head Office: Sacramento, CA.
Offices: Silicon Valley, CA.
Bethel, CT.
Austin, TX.
Beverly Farms, MA.
Lockport, NY.
Largo, FL.
Amsterdam, THE NETH.
Songtan-Shi, S. KOREA
- Burton Mechanical Contractors, Inc.**
Head Office: Rochester, IN.
Offices: Tampa, FL.
Los Angeles, CA.
- EBARA Environmental Corporation**
Greensburg, PA.
- E & M Energy, Inc.**
Erie, PA.
- Matsuzaka Company, (America), Inc.**
Head Office: New York, NY.
Office: San Jose, CA.

BRAZIL

- EBARA Indústrias Mecânicas e Comércio Ltda.**
Head Office: Bauru, S.P.
Office: São Paulo, S.P.

■ EUROPE

UNITED KINGDOM

- EBARA UK Limited**
London

ITALY

- EBARA Italia S.p.A.**
Cles

NETHERLANDS

- EBARA Netherlands B.V.**
Amsterdam

SPAIN

- EBARA EMICA, S.A.**
Madrid

GERMANY

- Matsuzaka GmbH**
Düsseldorf

■ ASIA

KOREA

- Seoul Office:** Seoul
- HYOSUNG-EBARA Co., Ltd.**
Head Office: Seoul
Plant: Changwon

PEOPLE'S REPUBLIC OF CHINA

- Beijing Office:** Beijing

TAIWAN R.O.C.

- Taipei Office:** Taipei
- EBARA KAILAY Environmental Engineering Co., Ltd.**
Taipei
- Ebara-Densan Taiwan Mfg. Co., Ltd.**
Taoyuen

PHILIPPINES

- Manila Office:** Manila

THAILAND

- Bangkok Office:** Bangkok

SINGAPORE

- EBARA Engineering Singapore Pte Ltd.**
Singapore

MALAYSIA

- EBARA Engineering (Malaysia) Sdn Bhd**
Kuala Lumpur

INDONESIA

- Jakarta Office:** Jakarta
- P.T. EBARA Indonesia**
Barat

INDIA

- KIRLOSKAR EBARA Pumps Ltd.**
Head Office: Pune
Plant: Savantpur, Maharashtra