



**EBARA**



SZ8001-V

# MIXED FLOW VOLUTE PUMP

## MODEL SZ





## APPLICATIONS

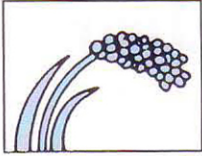

Irrigation

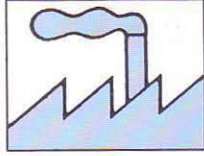

Industrial use

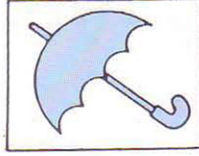

Drainage

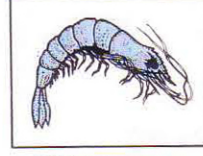

Shrimp eathern

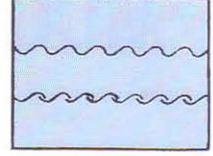

Flooding

## FEATURES

- HIGH EFFICIENCY
- LOW COST OPERATION
- ECONOMICS
- NON CLOGGING
- EASY MAINTENANCE

## SPECIFICATIONS

- TYPE : HORIZONTAL SHAFT MIXED FLOW VOLUTE PUMP
- IMPELLER : MIXED FLOW OPEN TYPE
- ROTATION : COUNTER CLOCKWISE WHEN VIEWED FROM END SHAFT COUPLING
- BEARING : BALL BEARING (SEALED BALL BEARING OR OIL BATH TYPE)
- FLANGE : JIS 10 Kg/Cm<sup>2</sup> (THICK TYPE)
- NOZZLE POSITION : STANDARD 200 - 250 SIDE SUCTION – TOP DISCHARGE  
 STANDARD 300 - 500 SIDE SUCTION – SIDE DISCHARGE  
 OPTIONAL 300 - 350 SIDE SUCTION – TOP DISCHARGE
- LIQUID : RIVER WATER, FRESH WATER
- TEMPERATURE LIQUID : BELOW 80° C

• Construction Bare shaft Pump

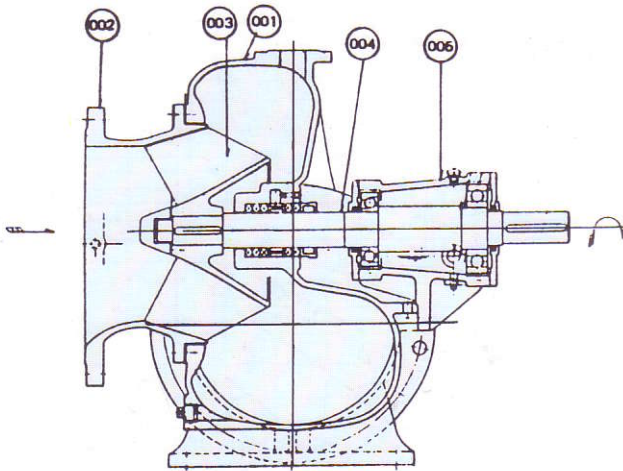

Size 300-500 mm

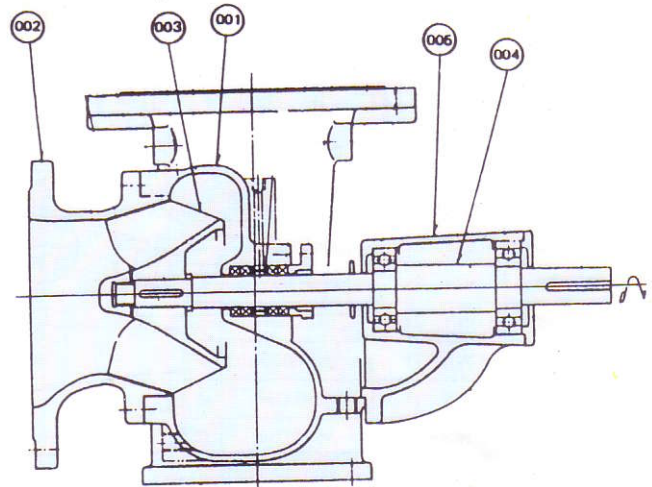

Size 200-350 mm

No.	Part Name	Material Standard	Qty./Unit
001	Casing	Cast iron (FC20)	1
002	Suction cover	Cast iron (FC20)	1
003	Impeller	Bronze (BC6)	1
004	Shaft	Stainless steel	1
005	Bearing housing	Cast iron (FC20)	1

• Outline Drawing  
Size 200-350 mm

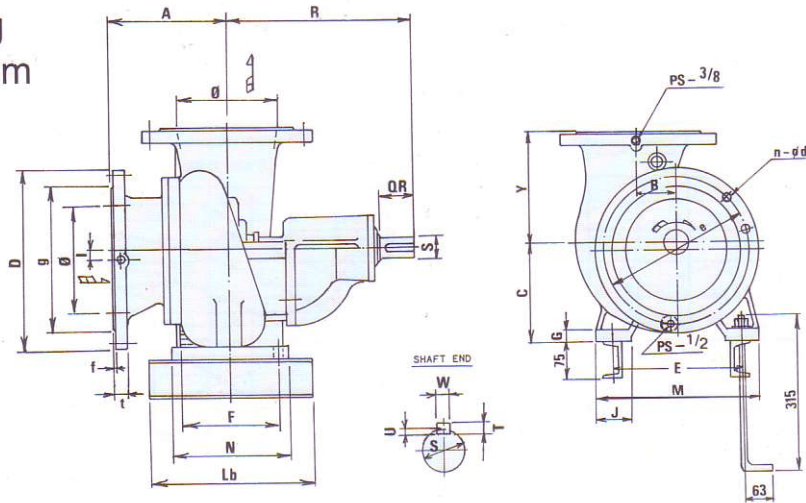

unit : mm

MODEL	PUMP DIMENSIONS														FLANGE DIMENSIONS						SHAFT DIMENSIONS					PUMP WEIGHT
	A	R	B	C	I	E	F	G	J	Lb	M	N	Y	Ø	D	g	e	n-d	t	f	S	QR	T	U	W	kg
200SZ	223,5	355	80	200	15	280	190	20	70	320	340	230	220	200 8	330	265	290	12 - 23	26	2	40	77	8	4,5	10	136
250SZ	288,5	380	100	240	15	330	235	22	80	380	400	280	260	250 10	400	325	355	12 - 23	30	2	40	78	8	4,5	10	145
300SZ	340	590	135	360	25	330	290	24	75	450	400	350	280	300 (12)	445	370	400	16 - 25	32	3	48	124	8	4,5	12	271
350SZ	390	680	155	350	20	430	350	26	105	550	520	420	330	340 (14)	490	415	445	16 - 25	34	3	55	153	8	4,5	12	325



# Size 300-500 mm

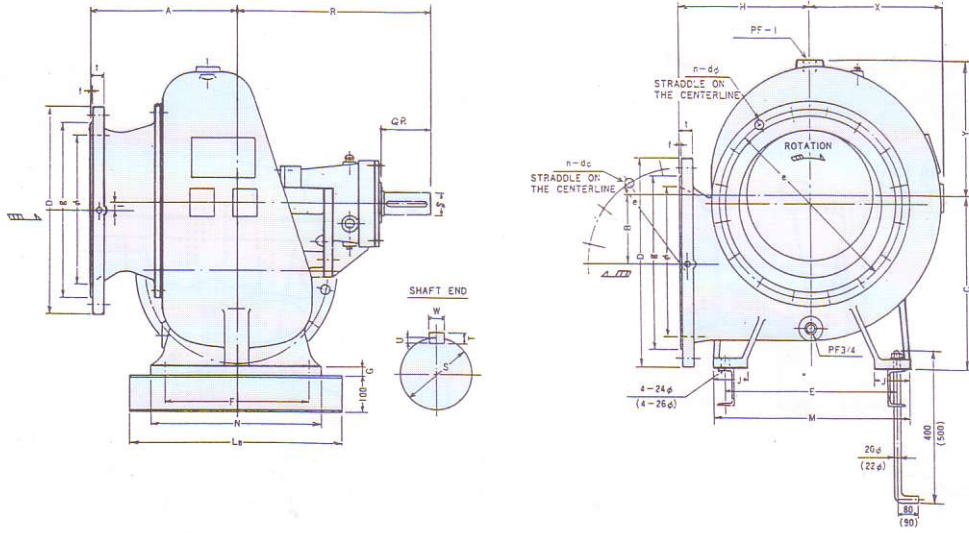

unit : mm

MODEL	PUMP DIMENSIONS														FLANGE DIMENSIONS					SHAFT DIMENSIONS					PUMP WEIGHT		
	A	R	H	C	I	E	F	G	J	Lb	M	N	X	Y	Ø	D	g	e	n-d	t	f	S	QR	T	U	W	kg
300SZ	340	590	280	360	25	330	290	24	75	450	400	350	280	257	300 (12")	445	370	400	16 - 25	32	3	48	124	8	4,5	12	220
350SZ	390	680	330	420	20	410	350	26	90	550	490	420	330	307	340 (14")	490	415	445	16 - 25	34	3	55	153	8	4,5	12	310
400SZ	430	770	370	470	25	490	410	28	100	600	570	480	381	364	400 (16")	560	475	510	16 - 27	36	3	65	180	10	5	15	497
500SZ	540	850	460	580	31	620	500	32	125	750	720	600	476	451	500 (20")	675	585	620	20 - 27	40	3	75	180	12	6	18	840

## PERFORMANCE CURVE

### • MODEL 200 SZ

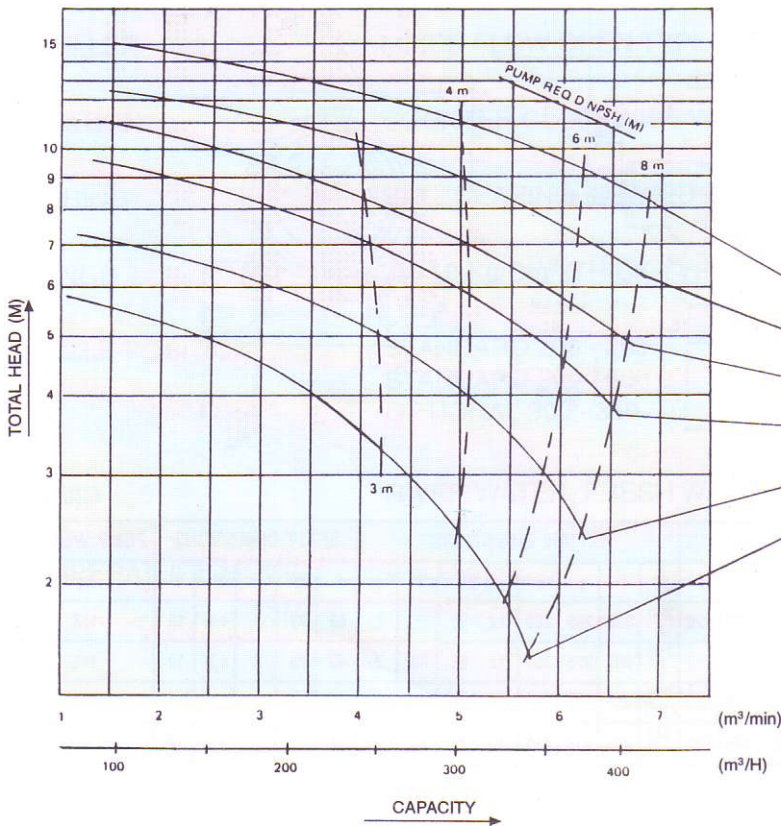

PUMP ROTATION, AND POWER REQUIREMENT

No.	Pump Rotation	Motor Output	Engine Output
1	1750 Rpm	15 KW	20 HP
2	1600 Rpm	11 KW	15 HP
3	1500 Rpm	11 KW	13 HP
4	1400 Rpm	7,5 KW	10 HP
5	1250 Rpm	5,5 KW	7,5 HP
6	1100 Rpm	3,7 KW	5,5 HP



## ● MODEL 250 SZ

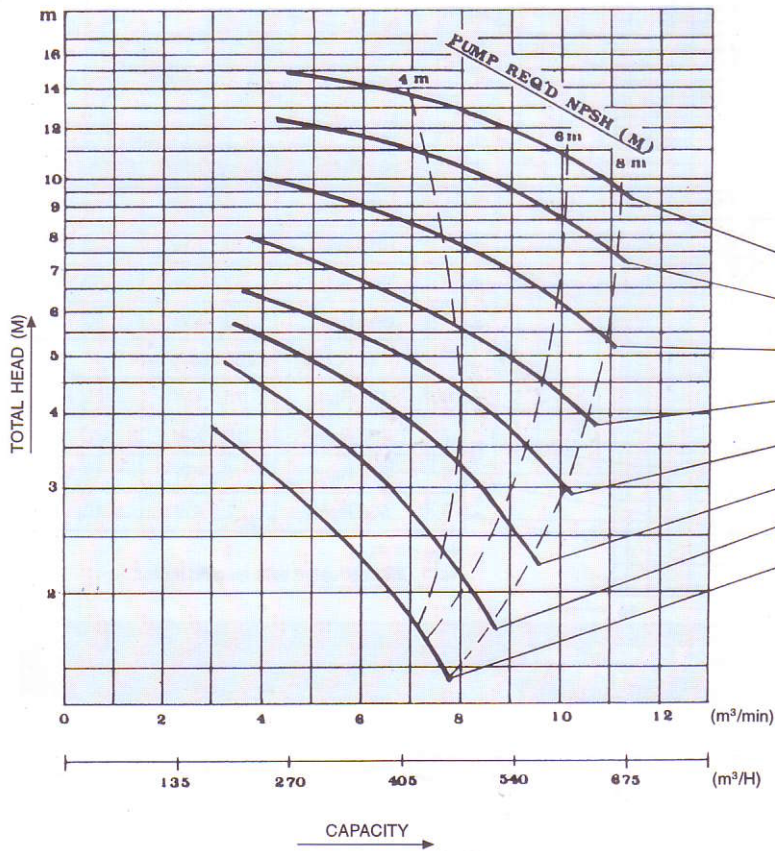

PUMP ROTATION, AND POWER REQUIREMENT

No.	Pump Rotation	Motor Output	Engine Output
1	1450 Rpm	30 KW	40 HP
2	1320 Rpm	22 KW	30 HP
3	1180 Rpm	15 KW	20 HP
4	1060 Rpm	11 KW	15 HP
5	980 Rpm	11 KW	13,5 HP
6	900 Rpm	7,5 KW	10 HP
7	830 Rpm	5,5 KW	7,5 HP
8	750 Rpm	3,7 KW	5 HP

Note :  
No. 1 Direct coupled with electric motor.

## ● MODEL 300 SZ

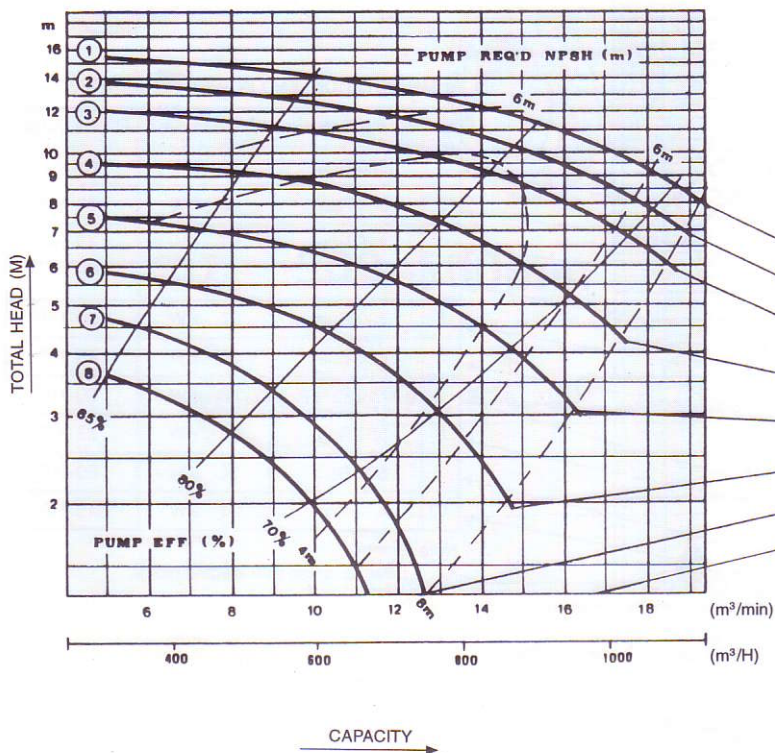

PUMP ROTATION, AND POWER REQUIREMENT

No.	Pump Rotation	Motor Output	Engine Output
1	1240 Rpm	45 KW	60 HP
2	1170 Rpm	37 KW	50 HP
3	1100 Rpm	30 KW	40 HP
4	980 Rpm	22 KW	30 HP
5	880 Rpm	15 KW	20 HP
6	780 Rpm	11 KW	15 HP
7	690 Rpm	7,5 KW	10 HP
8	620 Rpm	5,5 KW	7,5 HP

Note :  
No. 1 Direct coupled with electric motor.



# ● MODEL 350 SZ

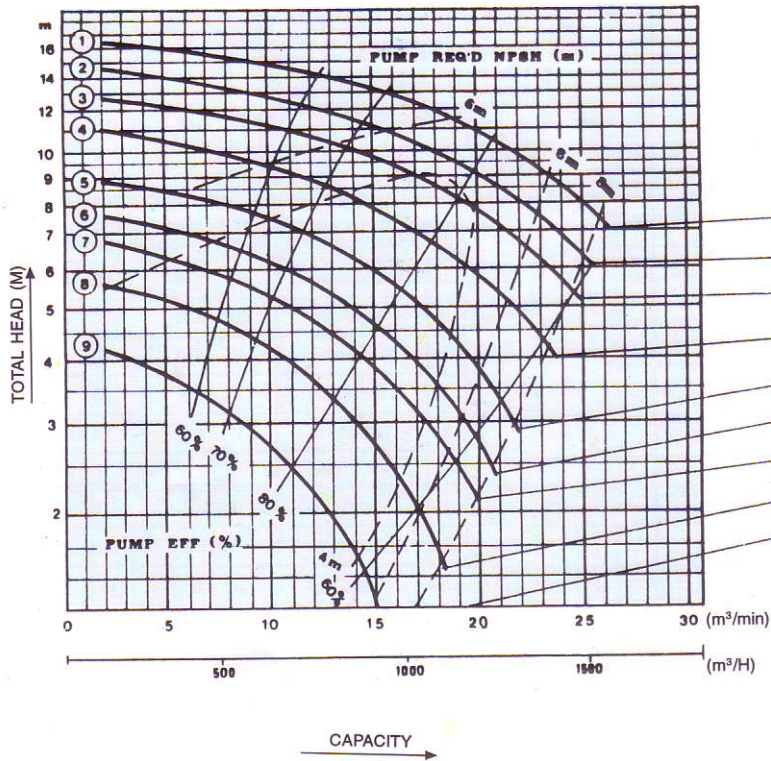

PUMP ROTATION, AND POWER REQUIREMENT

No.	Pump Rotation	Motor Output	Engine Output
1	1070 Rpm	55 KW	75 HP
2	1010 Rpm	45 KW	60 HP
3	950 Rpm	37 KW	50 HP
4	880 Rpm	30 KW	40 HP
5	795 Rpm	22 KW	30 HP
6	735 Rpm	18,5 KW	25 HP
7	700 Rpm	15 KW	20 HP
8	625 Rpm	11 KW	15 HP
9	550 Rpm	7,5 KW	10 HP

Note :  
No. 1 Direct coupled with electric motor.

# ● MODEL 400 SZ

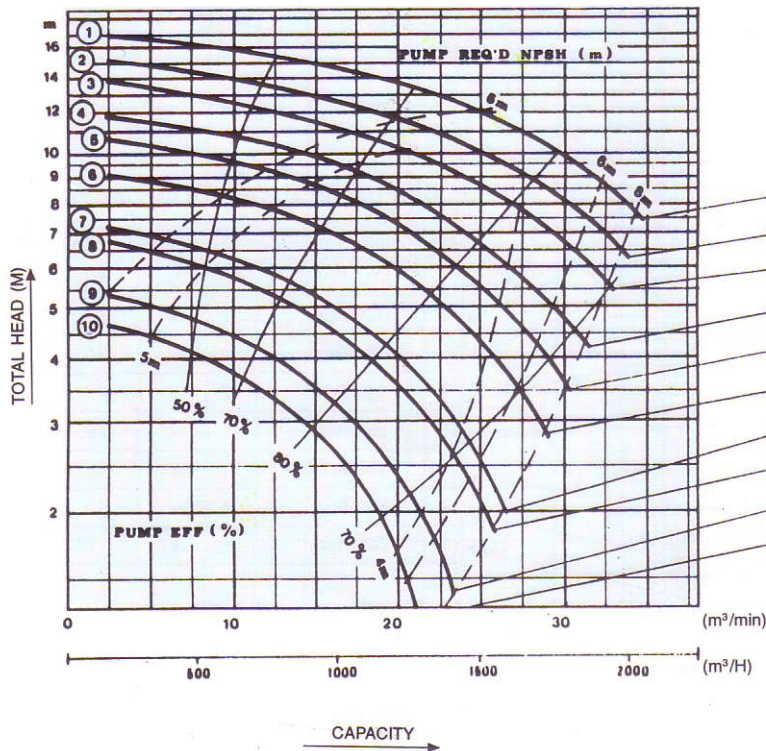

PUMP ROTATION, AND POWER REQUIREMENT

No.	Pump Rotation	Motor Output	Engine Output
1	930 Rpm	75 KW	100 HP
2	880 Rpm	60 KW	80 HP
3	825 Rpm	55 KW	75 HP
4	775 Rpm	45 KW	60 HP
5	730 Rpm	37 KW	50 HP
6	685 Rpm	30 KW	40 HP
7	610 Rpm	22 KW	30 HP
8	590 Rpm	18,5 KW	25 HP
9	530 Rpm	15 KW	20 HP
10	490 Rpm	11 KW	15 HP

Note :  
No. 1 Direct coupled with electric motor.



# ● MODEL 500 SZ

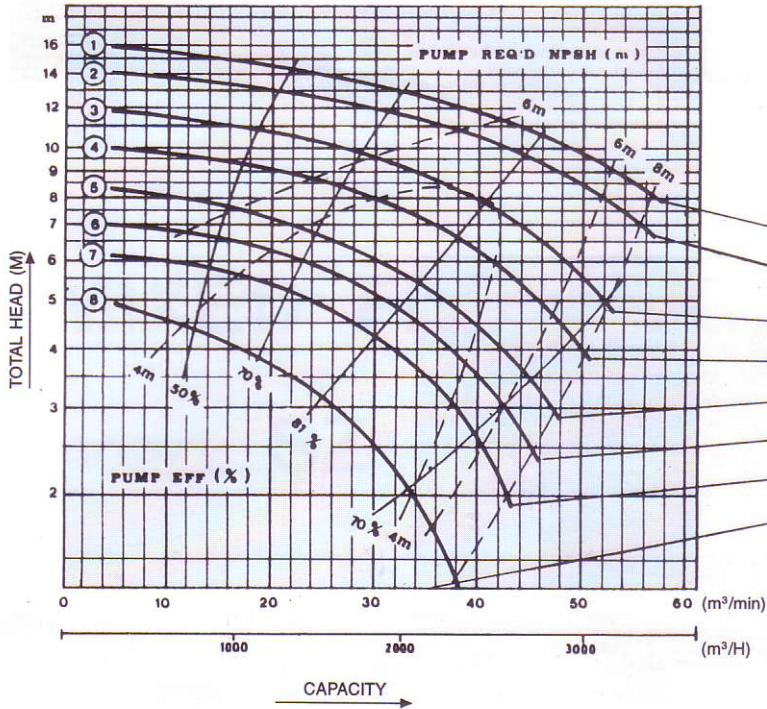

PUMP ROTATION, AND POWER REQUIREMENT

No.	Pump Rotation	Motor Output	Engine Output
1	735 Rpm	110 KW	150 HP
2	705 Rpm	95 KW	130 HP
3	640 Rpm	75 KW	100 HP
4	590 Rpm	55 KW	75 HP
5	535 Rpm	45 KW	60 HP
6	500 Rpm	37 KW	45 HP
7	470 Rpm	30 KW	40 HP
8	420 Rpm	22 KW	30 HP

Note :  
No. 1 Direct coupled with electric motor.

## DISASSEMBLY

### SIZE 200–350mm

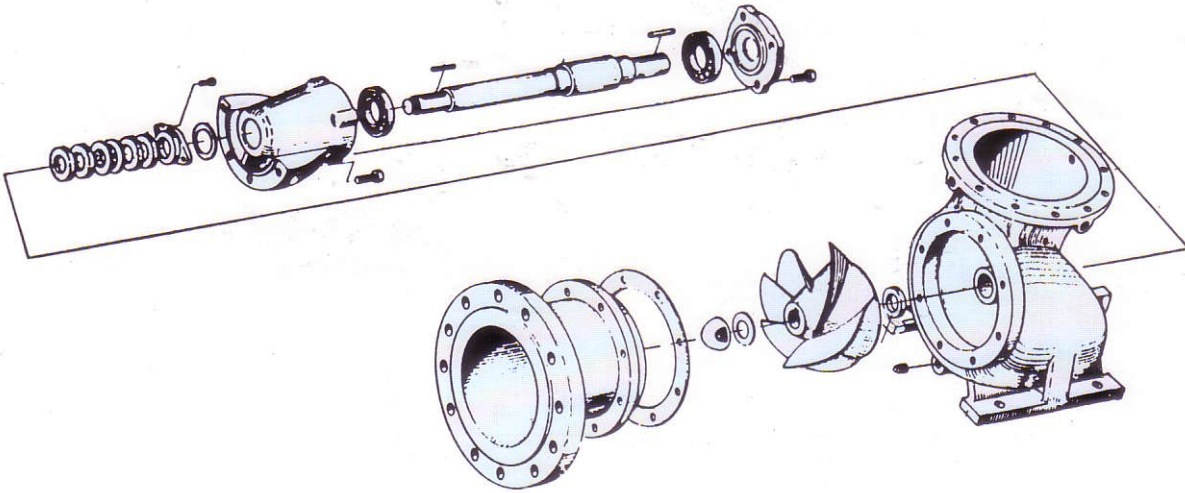

### SIZE 300–500mm

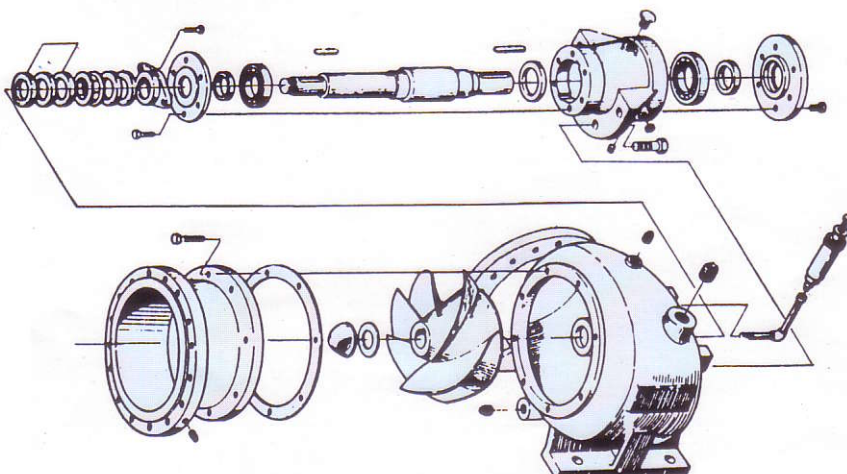



## OTHERS

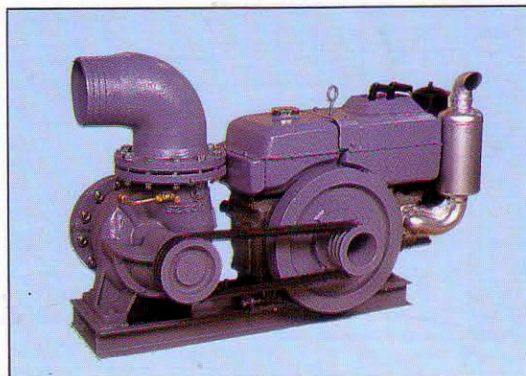

PUMP COUPLED WITH ENGINE

\* This picture doesn't show belt cover  
for safety belt cover should be install.

All specifications are subject to change without notice



### EBARA CORPORATION

Head Office, Tokyo  
International Division, Tokyo  
Singapore Office  
Beijing Office  
Bangkok Office  
Hanoi Office  
Jakarta Office  
Kuala Lumpur Office  
Manila Office  
Taipei Office  
Dubai Office

Phone: 81 - 3 - 3743 - 6111	
Phone: 81 - 3 - 5461 - 6111	
Phone: 65 - 862 - 3536	Fax: 65 - 861 - 0589
Phone: 86 - 10 - 6590 - 8150	Fax: 86 - 10 - 6590 - 8158
Phone: 66 - 2 - 216 - 4935	Fax: 66 - 2 - 216 - 4937
Phone: 84 - 4 - 826 - 3601	Fax: 84 - 4 - 826 - 3617
Phone: 62 - 21 - 8740852	Fax: 62 - 21 - 8740033
Phone: 603 - 5569 - 1655	Fax: 603 - 5569 - 3766
Phone: 63 - 2 - 816 - 7524	Fax: 63 - 2 - 817 - 6662
Phone: 886 - 2 - 567 - 1310	Fax: 886 - 2 - 567 - 1046
Phone: 971 - 4 - 883 - 8889	Fax: 971 - 4 - 883 - 5307

Distributor / Dealer